

Emeter v2 Quick Guide 2.06

rev. December 28 2008

See <http://media.hyperion.hk/dn/em2> for updates to documentation, PC software, and Firmware

Introduction

The Hyperion Emeter II can carry out an enormous range of functions related to Electric Powered models and small vehicles, and has been designed with ease of use as a prime objective. On-screen help, a menu system and friendly error messages all contribute to this objective while in the field or at the lab.

This Quick Guide describes the scope of Emeter II and how to make it work for you, in a sequence which matches the on-screen menus. The Emeter's own On-screen help is a subset of this information intended to answer most questions at the field. The full Emeter II User Manual (Download from link above) goes into greater depth with explanations of many of the issues surrounding Electric Power and Radio Control models.

The Emeter II System consists of two major components:

- The pocket sized case houses the display screen, an SD Card slot, buttons for menu navigation, a potentiometer to drive pulse-width devices such as servos and motor controllers, an optical tachometer, and an internal battery pack with onboard charger.
- A Remote Data Unit which, with its small size can be fitted to the power system (RC model, robot, scooter, etc...) to log data. At the end of the logging period, the captured data can be copied to the Emeter II for display, without the need for a Personal Computer.

In addition, the Emeter v2 comes with two cables in the box:

-- A **Data Cable** (aka "RDU Cable", #HP-EM2-4PINCBL). It has a locking Molex 4-pin connector on one side which fits the Emeter v2 at bottom-right port. The other side has 5-pin female connector (with one pin "blanked"). This side fits the RDU so that the RDU can transfer files to Emeter, and communicate during Bench testing or RDU setup. The same side also fits Hyperion TITAN series ESC, for programming via Emeter.

-- A **Power Cable** (#HP-EM2-PWRCBL) with 4.5mm plug on one side, and tinned wires on the other. The Emeter contains a 5-cell 750mAh NiMH battery inside, and an INTERNAL CHARGER. You should never connect a battery charger to this power input. Instead, simply use any 12V~15V DC power supply with 120mA or higher capacity (such as a 13.8V DC power supply, Automotive battery, or discarded 12V "Wall PS" from some old toy, router, etc). **Please take time now** to fit appropriate connectors to this cable, and plug in your Emeter to a 12-15V power source for charging. See details below for charge rate and time.

Terminology

RDU - The **Remote Data Unit** contains data storage, and sensors for measuring voltage, current, altitude, ambient temperature and other data. In addition the RDU has input/output connectivity to a receiver or pulse-width driver such that throttle position can be recorded or remote on/off of logging controlled. The RDU can record currents up to 150 amps, with a maximum of 70V. There are also optional sensors available for up to three external temperatures and phase tachometer for brushless motors.

Before using the RDU, it is necessary to solder on the connectors of your choice to the RED/BLACK wires marked INPUT (battery side) and LOAD (motor, etc) on RDU bottom. The connectors must be high-quality and matched in size to the maximum currents you expect to draw. Although the RDU is protected against accidental connection with polarity reversed, the ESC which is normally connected to the LOAD side of the RDU, is likely not protected and will be destroyed by reversed polarity. So take great care with connector polarity.

ESC - Electronic Speed Controller is used to vary the speed of the model's motors

BEC - Battery Eliminator Circuitry, optionally included in the ESC, is used to power receiver/servos from main power pack instead of a separate receiver pack

SD Card - is a mass data storage device which may also be used for transfer of data between a PC and the Emeter II, including:

- Emeter II and RDU firmware updates
- Files for On-line screen help
- Prop constants data
- Data logs
- Parameters for user-programmable servo or ESC drivers

An SD card is not included but is strongly suggested for complete functionality. Standard (or Mini/Micro in adapter) SD SDHC cards up to 4Gb are supported. They must be formatted as FAT16 or FAT32.

Phase Tachometer sensor - (option part # HP-EM2-TACHBL) has a single wire which should be connected to any of the three wires into a brushless motor, and the 3 pin plug which fits the RDU socket labelled 'RPM'.

External Temp 1,2,3 sensors - (option parts #HP-EM2-TMP1 and #HP-EM2-TMP23) Note that Temp#1 must be purchased in order to add temps #2 and #3, as only TEMP#1 connects direct to RDU (2,3 connect with #1).

On Screen Help and Navigation

Features are accessed by selection from a multi-level menu. Button numbers are shown in quotes for example 'A', 'B', 'C' or 'D' and have an abbreviated description on the bottom row of the display. Button 'A' on the MAIN menu will display Tips on RDU and Emeter II firmware version upgrades. Navigation through the menus is achieved by pressing 'D' until the required menu item shows in larger characters. Once this occurs,

- press 'B' to display screen help relating to the selected function or
- press 'C' to go to the selected function.

There are two basic modes of operation – 'Bench-Test' mode in which the RDU and the Emeter II are connected for use together, and 'In-Action' mode where the RDU is used alone. In Bench-Test mode, data is recorded directly to the SD card, whereas In-Action mode stores the data in the RDU from where it is later copied to the Emeter II SD card. After switching the Emeter II on, the function which was in use at the previous switch off time will re-appear. In most cases, 'A' will cause a return to the previous, higher menu item or screen. Certain actions may cause deletion of data which could be critical. You will be warned if this is the case and requested to confirm the action.

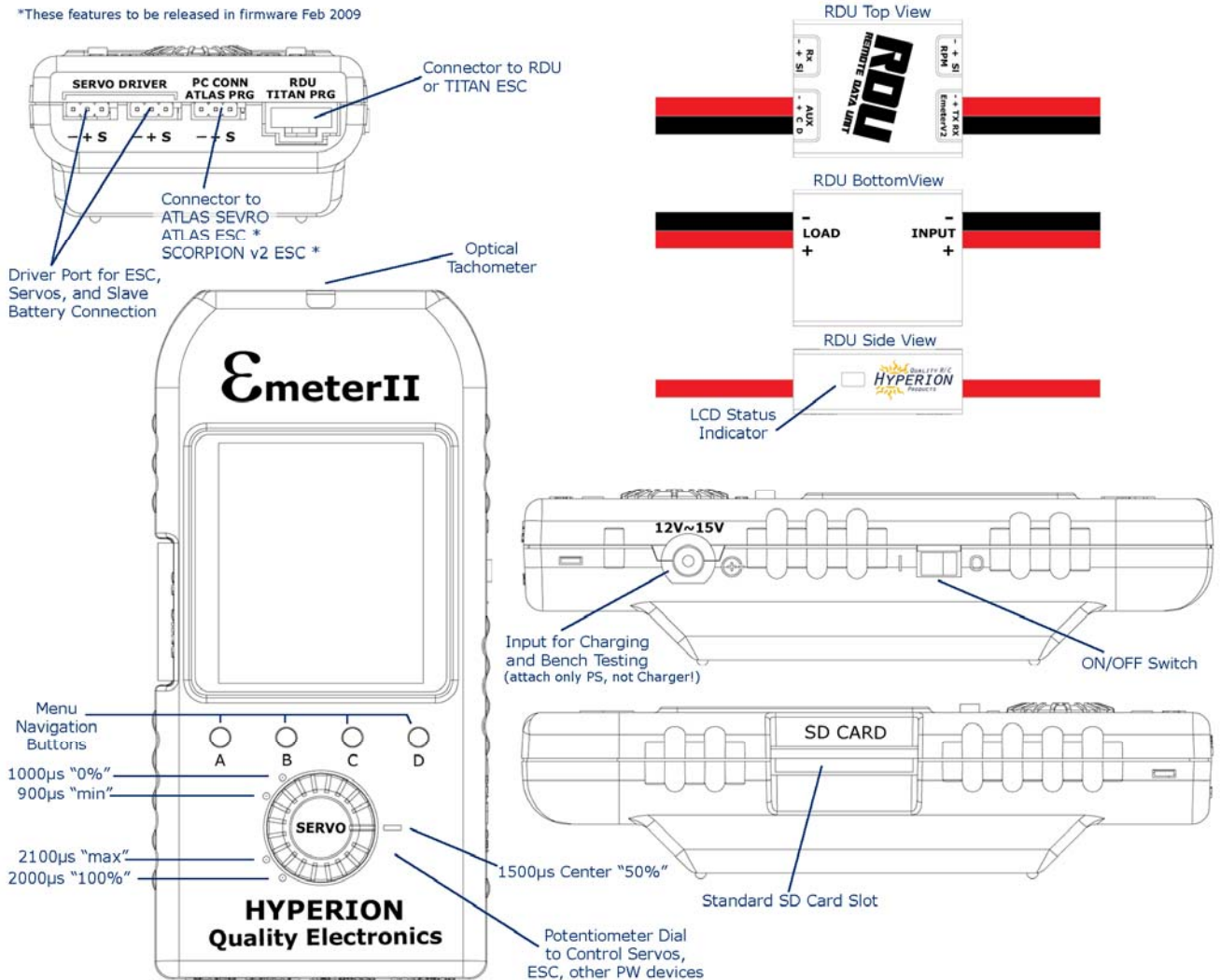

OPERATION NOTES

EMETER BASIC SETUP			
	Function	Screen/Mode	Cables/Wiring
1.1	Internal battery Charging		12-15 volt supply with the supplied 4.5mm plug
<p>The Emeter II will automatically charge while connected to 12-15V PS whether the unit is in use, or switched off. The Emeter can be used while connected to 12-15V power source (i.e. during bench testing can be left connected) Charging will occur at 85 ma and take 9 - 12 hours at this rate from a fully discharged state. The battery will last between 18 and 50 hours, depending on use of screen backlight, connection to RDU and other factors. Main menu shows internal battery charge state indicator. Reconnect to 12-15V PS before this falls to 0%. The date and time will need to be reset if the internal battery is allowed to go flat.</p>			
1.2	Set Date/Time	MAIN>EMETER SETUP	
<p>Press 'D' (next) to move to date or time lines. Press 'B' or 'C' to decrease or increase the fields as required. Hold button down for accelerated change. These fields are used to add a timestamp to log files or snapshots (see 4.1 - 4.3).</p>			

ACCUMULATED and PEAK DATA			
	Function	Screen/Mode	Cables/Wiring
3.1	<i>Capacity mAh Input</i>	<i>READINGS>BATTERY or READINGS>ANALYSER Accumulates even when on other screens</i>	<i>RDU + RDU cable</i>
From 0 – 65000 mA-h. Records charged capacity automatically, whenever current is flowing through the RDU. Press 'C' to clear mA-h In when on BATTERY screen. NOTE: Capacity will continue to log in the RDU even if the Emeter II is switched off.			
3.2	<i>Capacity mAh Output</i>	<i>READINGS>BATTERY or READINGS>ANALYSER Accumulates even when on other screens</i>	<i>RDU + RDU cable</i>
From 0~65000 mA-h. Records discharged capacity automatically, whenever current is flowing through the RDU. Press 'C' to clear mA-h 'Out' when on BATTERY screen. Note: Capacity will continue to log in the RDU even if the Emeter II is switched off.			
3.3	<i>Max Volts</i>	<i>READINGS>PEAKS</i>	<i>RDU + RDU cable</i>
Peak values recorded for whole session or from when 'B' (Clr) pressed. These values are lost when switching the Emeter II off unless saved to SNAPSHOT 1 – 8			
3.4	<i>Min Volts</i>	<i>READINGS>PEAKS</i>	<i>RDU + RDU cable</i>
As above. Useful to assist in protecting batteries from over-discharge.			
3.5	<i>Max Amps</i>	<i>READINGS>PEAKS</i>	<i>RDU + RDU cable</i>
As above. Useful to assist in protecting batteries and ESC from over-current conditions.			
3.6	<i>Max RPM</i>	<i>READINGS>PEAKS</i>	<i>RDU + RDU cable</i>
Peak values recorded for whole session or until 'B' (Clr) pressed.			
3.7	<i>Pack resistance Ohms</i>	<i>READINGS>PEAKS</i>	<i>RDU + RDU cable</i>
Start discharge, press 'B' (Clr), stop discharge or Press 'B' (Clr), start and stop discharge. Resistance will be shown in ohms			
SNAPSHOTS for short term saving of readings			
4.1	<i>Hold Display</i>	<i>On TACHO, PEAKS, ANALYSER, BATTERY screens</i>	<i>RDU + RDU cable</i>
Press 'D' to hold – 2 nd press continues, as if no hold took place			
4.2	<i>Save snapshot</i>	<i>As for Hold</i>	<i>RDU + RDU cable</i>
Press 'C' to save in one of 8 SNAPSHOT locations for later recall, select SNAPSHOT 1 to 8 by pressing 'D', if required. Press 'C' again to resume original activity. Data stored in first empty SNAPSHOT location by default. Snapshots are retained when the Emeter II is turned off, but for long term data retention, see data logging facility			
4.3	<i>Snapshot Recall-Clear</i>	<i>READINGS>SNAPSHOTS</i>	<i>None</i>
Shows up to 8 snapshots taken from ANALYSER, BATTERY, SNAPSHOTS or TACHO screens These are stored internally, not on the SD card. Press 'D' to scroll through snapshot 1 to 8. Display is in format of screen from which the save was originally made. For ANALYSER or TACHO data press 'B' to view or specify Prop. constants. If these exist, then the calculated efficiency and/or propeller thrust in grams will show. Clear snapshot by pressing 'C'			
PROP CONSTANTS for calculation of motor efficiency and thrust			
	Function	Screen/Mode	Cables/Wiring
5.1	<i>Prop Constant Background</i>		
Prop constants can be used to calculate motor/ESC power/efficiency and also thrust for given RPM. See PROP TALK tutorial in Hyperion Website at www.hyperion.hk/dn/em2 . Emeter II can look up prop constants from a PROPS.TXT file held on the SD Card or will accept constants entered manually onto the CONSTANTS screen. The latter are given the name 'Other'. For either case, the last-used propeller details are retained for subsequent power, efficiency and thrust calculations			
5.2	<i>Prop Constant Viewing</i>	<i>READINGS>PROP CONST or READINGS>ANALYSER> button 'B' (Prop) or READINGS>TACHO> button 'B' (Prop)</i>	<i>SD Card</i>
If SD Card contains PROPS.TXT file, browse props via buttons 'B' (Dec) and 'C' (Inc). To select required file press 'A' (Save)			
5.3	<i>Prop Constant Entry</i>	<i>READINGS>PROP CONST or READINGS>ANALYSER> button 'B' (Prop) or READINGS>TACHO> button 'B' (Prop)</i>	
Press 'D' (next) to move to Power Constant field, use 'D' to move to figure to be entered and 'B' or 'C' to change to required value. Use 'D' to move to next figure and repeat process in the same way. Once numbers are correct, press 'A' to save for all future calculations until changed and saved again. Prop name will change to 'Other'			
5.4	<i>Prop Constant Entry Notes</i>		
Motor output power, efficiency and thrust figures are not calculated for In-Action mode since propeller constants do not apply to moving models. Only Bench-test mode can record power, efficiency and thrust. See manual for details.			

DATA LOGGING for long term save of data		
<i>Function</i>	<i>Screen/Mode</i>	<i>Cables/Wiring</i>
<p>6.1 <i>Data Logging Bench-Test mode</i></p> <p>Press 'C' to log readings to SD card or to cease logging under full user control. Each start creates a new log file with unique file number and showing date and time. Blinking message on screen acts as recording indicator.</p> <p>Warning, do NOT power off the Emeter II while logging is in progress.</p> <p>Press 'C' on BATTERY or ANALYSER screens to stop logging first.</p>	<p><i>READINGS>ANALYSER or READINGS > BATTERY</i></p>	<p><i>RDU + RDU cable + optional RPM or temperature sensors</i></p>
<p>6.2 <i>Set RDU data logging parameters for the In-Action mode</i></p> <p>Set Trigger type for start of logging:</p> <ul style="list-style-type: none"> Amps – start logging when actual current exceeds specified trigger amps If amps fall below trigger level, then logging will stop if the recording time has expired. Increase amps above trigger current to resume logging. There will be multiple sets of data readings – one set for each time the actual current rises above then falls below the specified trigger amps. These different sets will all be down-loaded to the SD card as a single file. The time display resets to 0 at the start of each set. For continuous logging after amps start, set expiry record time = 0 or very high. If the RDU is unplugged from the main power source, then, once the RDU and power source are re-connected, a new data log file will be created. The download action, if chosen, will copy all files from the RDU to the SD card Time – this option is used for motor-less models which cannot use an AMPS based trigger. Logging begins once start delay seconds have elapsed after RDU connected to main Power Pack and continues until the RDU is disconnected or the record time expires Manual – logging controlled by signal from spare receiver channel. Pulse width < 1300 µs. will stop logging and > 1700 µs starts logging <p>Set recording expiry time (in secs.) for data logging session or zero for unlimited length Set sample rate from 4 per second to 8 secs. per sample. This sample rate applies to both In-Action and Bench-Test modes. Save logging parameters by pressing 'A'</p>	<p><i>MAIN MENU>RDU SETUP</i></p>	<p><i>RDU + RDU cable</i></p>
<p>6.3 <i>Set up RDU logging of:</i></p> <p><i>Amps, Volts, RPM, Ambient temp, 3 other temps, height</i></p> <p>- Connect optional rpm sensor to RDU RPM port and any one of brushless motor input leads. Note that the ambient temperature and height will be recorded automatically by sensors built in to the RDU. Connect option temp. sensor #1 to the 4 pin plug on the RDU marked 'AUX', and connect option Temps #2 and #3 to Temp #1. Where possible, use adhesive tape to prevent movement between the sensors and target to ensure good contact (example, motor, power pack and ESC). - Connect RDU main power wires to ESC. When ready to run model, connect RDU to power pack. Green LED should flash on RDU at the sample rate. Green LED changes to red whilst logging is in progress. Time based logging will stop when the Record Secs. on the RDU SET-UP have elapsed or the RDU is disconnected from the model's power-pack.</p> <p>Amps triggered logging will stop when the Record Secs have elapsed AND the current drops below the trigger amps. Logging will resume again if the current rises above the trigger amps; a fresh Record Secs time will apply</p>		<p><i>RDU + optional RPM and temperature sensors</i></p> <p><i>NO RDU cable from RDU to Emeter II</i></p> <p><i>3 wire cable from spare Rx channel to RDU Rx input (for manual logging start)</i></p>
<p>6.4 <i>Download Data to Emeter II</i></p> <p>Connect RDU to Emeter II via RDU cable Switch Emeter II on – should receive message 'found dataset – download now?'</p> <p>Reply 'Yes' by pressing 'D' or 'A' to defer the transfer of data held in the RDU until later The progressive status of download is shown and the data is downloaded to the SD Card with a unique file number and showing the date and time of the download</p>	<p><i>At switch on-time an automatic message appears if RDU carries data which has not been downloaded</i></p>	<p><i>RDU + SD Card + RDU cable</i></p>
<p>6.5 <i>View log files</i></p> <p>Use 'D' to browse to required log file. Log files have a unique file number and show the date and time stamps which are set to the date and the time of:</p> <ul style="list-style-type: none"> the download from RDU to Emeter II or the time when a Bench-Test log file was created <p>Logged data for both In-Action and Bench-Test consists of:</p>	<p><i>MAIN>LOG FILES</i></p>	<p><i>SD Card</i></p> <p>Time Volts Amps Rpm Watts Input Height</p> <p>Ma-h out Ma-h In Ambient Temp Sensor 1 temp Sensor 2 temp Sensor 3 temp</p>
<p>6.6 <i>Graphing of log files</i></p> <p>After highlighting a Log File from the list, press 'C' to select. The Graph function will allow any two of volts, amps, height and rpm to be plotted against time. For full details, refer to Emeter II Manual.</p>	<p><i>MAIN>LOG FILES</i></p>	<p><i>SD Card</i></p>

TIMERS & STOPWATCHES

General notes on Timers and Stopwatches - On entering any one of the three stopwatch screens, a check is made for any previous timing data for this particular stopwatch mode. If this exists, then the stopwatch will display the previous data. If the data was initially captured using a different stopwatch mode, then a warning is issued and the option to clear data is given. All stopwatch and countdown functions will remain running while using other Emeter II screens.

	<i>Function</i>	<i>Screen/Mode</i>	<i>Cables/Wiring</i>
7.1	<i>Stopwatch/lap count mode</i>	<i>MAIN>STOPWATCHES>LAP COUNT</i>	<i>None</i>
<p>Use to time any competition for which individual lap times and counts are needed. Records up to 100 'events' which may be lap times or stopwatch starts/stops. Start stopwatch with Button D - shows time as Primary (PRIM) Press button C at end of each lap. Lap time and the lap number show on lower half of screen. SPLT is the value of Primary time as of last button C press. Press button D to pause both Primary and lap timers. Press 'C' to recall laps from beginning</p>			
7.2	<i>Stopwatch- Dual Mode</i>	<i>MAIN>STOPWATCHES>DUAL MODE</i>	<i>None</i>
<p>Use for timing one activity within a second for example one individual lap within a multi-lap race Use 'C' to start/stop the secondary stopwatch and 'D' for primary stopwatch Secondary watch only runs whilst primary is running All events such as watch starts and stops are included in the list and may be recalled later if the Emeter II is switched to another function</p>			
7.3	<i>Stopwatch-Auto Mode</i>	<i>MAIN>STOPWATCHES>AUTO MODE</i>	<i>None</i>
<p>Same as Dual Mode, except that a single push of 'D' will automatically start both watches</p>			
7.4	<i>Count Down Timer</i>	<i>MAIN>STOPWATCHES>COUNT DOWN</i>	<i>None</i>
<p>Press 'B' (set) followed by 'B' or 'C' (increase or decrease) to change countdown start time. Hold these buttons down for accelerated change. Press 'D' to save - current time will be reset to countdown start time. Press 'D' to start countdown and 'D' a second time to stop/pause if required. When the countdown timer is running, pressing 'A' will allow use of most other Emeter II functions, such as Tacho or servo test without interrupting the countdown. At the end of the specified time: A 3-second-long beep will sound even if the Emeter II is in use on a different screen/function The current time will start increasing 'TIME OVER' will be displayed</p>			

SERVO and ESC programming and testing

8.1	<i>Titan ESC Programmer</i>	<i>MAIN>PROGRAMMING>TITAN PROG</i>	<i>Unplug Emeter II-RDU cable from RDU Plug RDU cable into ESC</i>
<p>Connect 4 wire cable from Emeter II to ESC and press 'D' (connect). Emeter II will display all settings which may be changed. If display fails to appear, check the polarity and fit of the plugs. Press 'D' to move to required parameter and 'B' (Configure) to change the value. Press 'A' to save new settings.</p>			
8.2	Feature Not Yet Released - Menu Slot intended for programming 2009 Hyperion ATLAS ESC Series		
8.3	<i>Atlas Digital Servo Programming</i>	<i>MAIN>ESC/SERVO>SERVO PROG</i>	
<p>Plug in digital servo as per on-screen diagram. Press 'D' and, by using 'B' or 'C', make changes to:</p> <ul style="list-style-type: none"> • Direction • Deflection • Speed • Centre • Deadband width <p>Save changes with 'A'</p>			
8.4	<i>Servo Cycle Testing - simple start/end</i>	<i>MAIN>SERVO TESTER</i>	<i>Servo and Rx battery</i>
<p>Plug in servo and receiver battery as per on-screen diagram. Note, servo and battery sockets are interchangeable. From EM firmware release 2.06 onwards, there are two alternative techniques for specifying the test profile:</p> <ul style="list-style-type: none"> • Simple start/end point spec. with servo cycling between these two limits • User defined profile: created on a PC and loaded onto the SD Card, or create directly on the Emeter II. (see next section) <p>Simple start/end point. As instructed on the screen, move the potentiometer (pot) to the start position (0%) and press 'D' (next). Move pot to end position (100%) and press 'D' (Start). SEE DIAGRAM PG. 2 Both the start and end positions will display the pulse width which will be in the approximate range 1000 - 2000 microseconds The servo will cycle between the two end points. Press 'C' to stop cycle testing</p>			

SERVO and ESC programming and testing (continued)		
<i>Function</i>	<i>Screen/Mode</i>	<i>Cables/Wiring</i>
8.5 <i>Servo Testing by Profile</i>	<i>MAIN>SERVO TESTER</i>	<i>Servo and 4.8-6.0V Rx battery</i>
<p>Creation of a test profile. A test profile consists of a series of records, each containing a signal pulse width in microsecs and a delay time in milliseconds. This tells the servo to what position it should move and for how long it should stay there. The profile itself can be created on a Personal Computer as a simple text file, but must have a .dat extension and must sit in the data directory on the SD card when in use on Emeter. A header record is followed by any number of details, for example: PW-uS, DELAY-mS 00911, 00100 01000, 00100</p> <p>Alternatively, create the profile directly on the Emeter II as follows: From the SERVO TESTER screen, move to the OPEN PROFILE screen by pressing 'B' Load, and then to the NEW PROFILE by 'B', New. This screen allows you to specify the Pulse Widths and Delay Times by turning the pot. They will then be given a unique number and stored on the SD card for future use. The Profile files may be renamed to a more meaningful name up to 8 characters in length on the PC.</p> <p>Use of existing profile. When on the SERVO TESTER screen press 'B' (Load) to display all known test Profiles. Press 'D' to browse through the list and 'C' (go) to pick.</p> <p>Two parameters can be set by pressing 'C' Mode. The 'Repeats' parameter determines whether the test profile is to be executed continuously or once only, and the second controls data logging. Press 'C' to step through the four permutations for the one which you want. The defaults are Repeats 'yes' and 'logging no'. You now have the option to start the servo test by pressing 'D' (start)</p> <p>Deletion of unwanted profile. PROFILE_TEST screen after picking profile, press 'B' delete and 'D' to confirm deletion.</p>		
8.6 <i>ESC Driver - Automatic</i>	<i>MAIN>SERVO TESTER</i>	<i>Servo and Rx battery</i>
<p>This is identical to the above servo testing from a profile, except that the ESC replaces the servo. It is not possible to run the ANALYSER screen at the same time as PROFILE TEST, however from the latter, it is possible to control data logging by pressing 'C' Once logging has started, press 'D' to start running the test profile. Press 'C' again to stop logging. The results can subsequently be played back on the Log Files screens.</p> <p>We strongly recommend that any test profile which is to be used for driving an ESC and a motor should have the first few seconds in the profile set to a motor-off signal such as 950 uS. If, during a profile controlled ESC motor test, there is an urgent need to terminate the run quickly, then it is only necessary to press 'D' Stop. This will cause processing to go back to the first data record in the profile test file (which corresponds to motor off) and to wait there for the next action by the user</p>		
8.7 <i>Servo/ESC Driver Manual</i>	<i>From any screen at any time</i>	<i>ESC (opto esc require 4.8-6v Rx battery)</i>
<p>Connect Emeter II, Rx battery and servo or ESC as for Servo Cycle Testing, but exit from the cycle testing screen. Rx battery MUST BE LEFT OUT if the ESC has BEC circuitry, UNLESS the +ve wire to the ESC is disconnected Set the Emeter II pot. to the throttle closed position - fully anticlockwise (Futaba may need clockwise). For model aircraft, initially test for correct wiring and functioning with no propeller, as a safety precaution. Turn pot. to drive servo. Note, the servo driver is opto-isolated and may be used independently of, or combined with, any other Emeter II functions. See diagram at end of this document for more details.</p>		

FIRMWARE UPGRADE and CALIBRATION		
<i>Function</i>	<i>Screen/Mode</i>	<i>Cables/Wiring</i>
9.1 <i>Calibrate volts</i>	<i>MAIN>RDU SETUP</i> <i>Hold 'D' for 3 secs. to allow access to</i> <i>Upgrade and Calibrate functions</i>	<i>RDU + RDU cable</i>
<p>Plug RDU into power source with known voltage. Increment/decrement to match voltage. Save twice</p>		
9.2 <i>Calibrate Current (amps)</i>		
<p>Plug RDU into power source. Discharge at known current. Increment/decrement to match amps. Save twice.</p>		
9.3 <i>Upgrade Emeter II</i> <i>Firmware version</i>	<i>Before switch-on, press Buttons 'A', 'B', 'C'</i> <i>and 'D' while switching power to Emeter II</i>	<i>SD card</i>
<p>Firmware loader process checks for file EMFW.bin on SD card and, if found, loads the new firmware version into the Emeter II.</p>		
9.4 <i>Upgrade RDU</i> <i>Firmware version</i>	<i>MAIN>RDU SETUP</i> <i>Hold 'D' for 3 secs. to allow access to RDU</i> <i>Upgrade function</i>	<i>SD card + RDU + RDU Cable</i>
<p>Firmware loader process checks for file RDUFW.bin on SD card and, if found, asks the user for confirmation before upgrade.</p>		

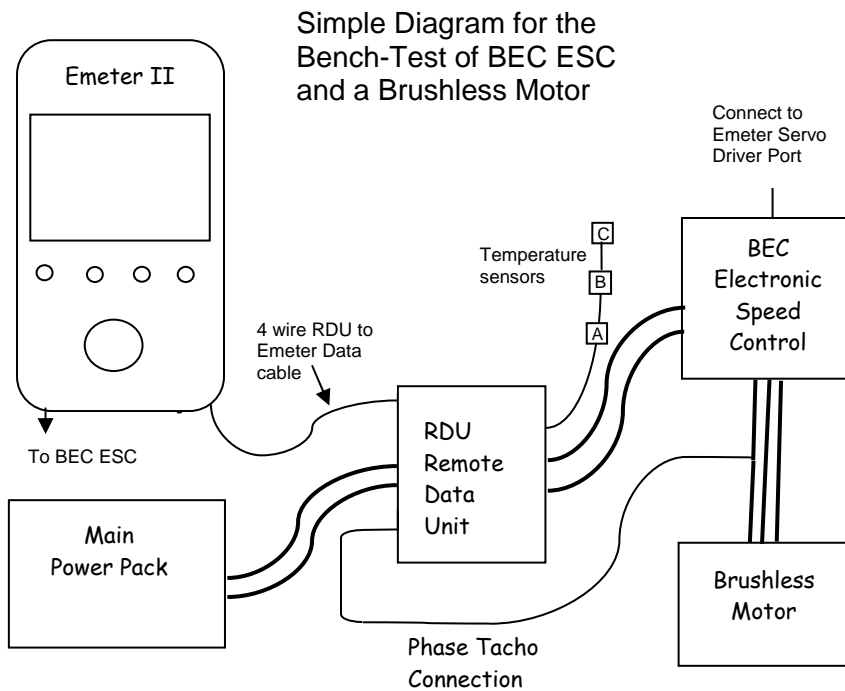

Also see <http://media.hyperion.hk/dn/em2> for the "EmeterII Suite" PC Software, which allows direct programming of RDU parameters, and log file downloads from SD Card or direct from the RDU. The Suite also contains graphing functions, and will soon support test profile creation for upload to the Emeter.

All the Best!

The Hyperion Team
tech@hyperion.hk

WARRANTY

Emeter and RDU are guaranteed to be free from defects in materials and workmanship for a period of one calendar year from date of purchase.

Damage due physical shock (dropping on the floor, etc), inappropriate power supply (battery charger, etc!), water, moisture, over-voltage or over-current operation, and humidity are specifically NOT covered by warranty.

Your selling dealer is your first point of contact for warranty issues.

Return postage costs are the responsibility of the user in all cases. Submit copy of original receipt with the return.

Returned units should be examined by the Hyperion dealer's tech department within 1 week of arrival, maximum, and contact made with the user to explain the findings.

REPAIR/REPLACEMENT DUE TO NON-WARRANTY ISSUES:

Due to the nature of the miniature electronics employed, and high cost of hand labor and shipping involved, it is not economically feasible to repair electronics in many cases. Instead, we offer a blanket exchange policy at 55% of the US\$ original suggested retail price (plus any taxes due in your area, and return shipping). In the event that your Emeter/RDU is user damaged and warranty will not apply, please contact your selling dealer to obtain the correct return shipping address, for exchange under this program.