

LAYOUT and OPERATION FLOW CHARTS (v4.6+ firmware versions)

EOS DUO Series Layout

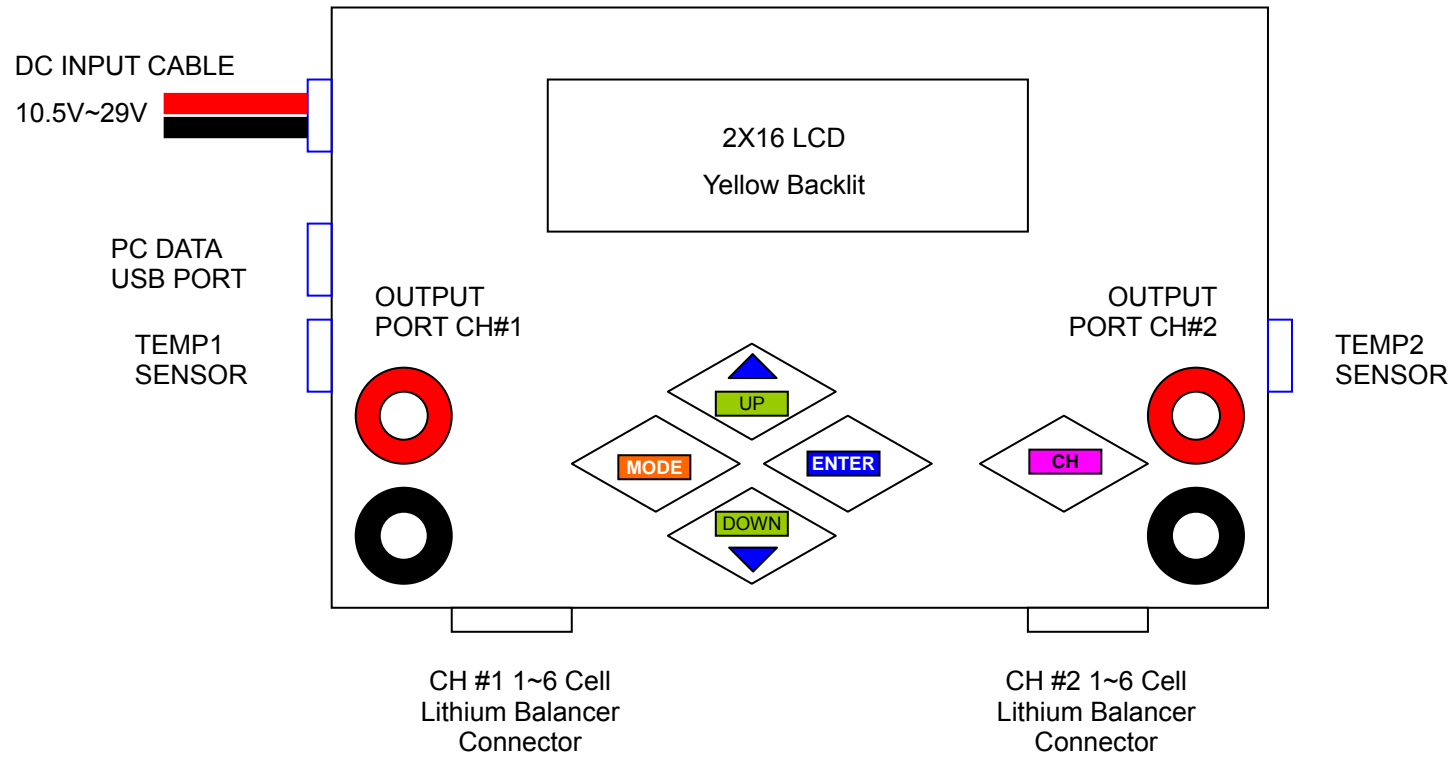

EOS NET Series Layout (showing also Networked for SYNC MODE)

* Note that NET3-AD (ac/dc) is 10.5V~15.0V DC input. All other NET/DUO are 10.5V~29.0V.

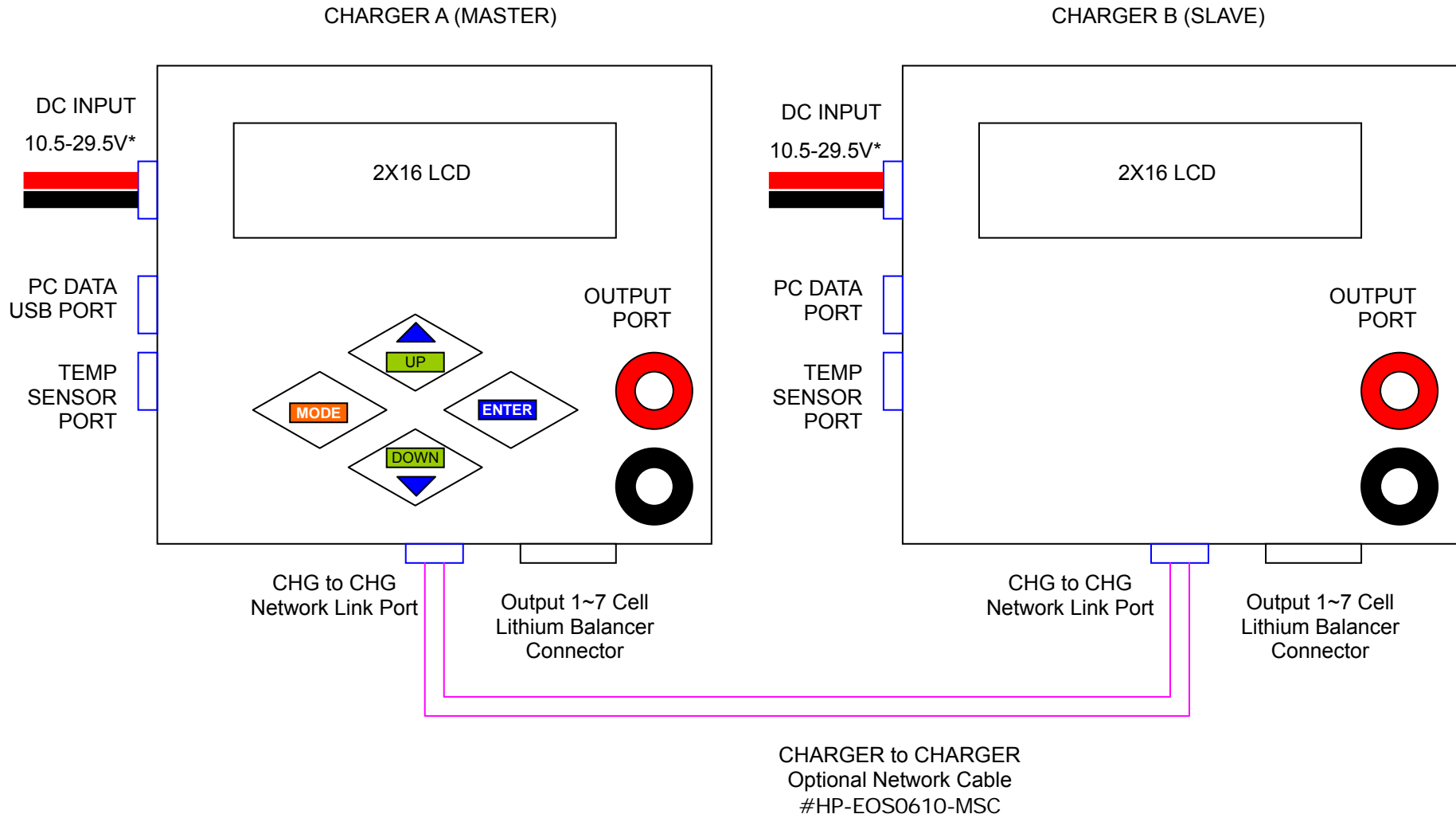

(1) MAIN MENU FLOW

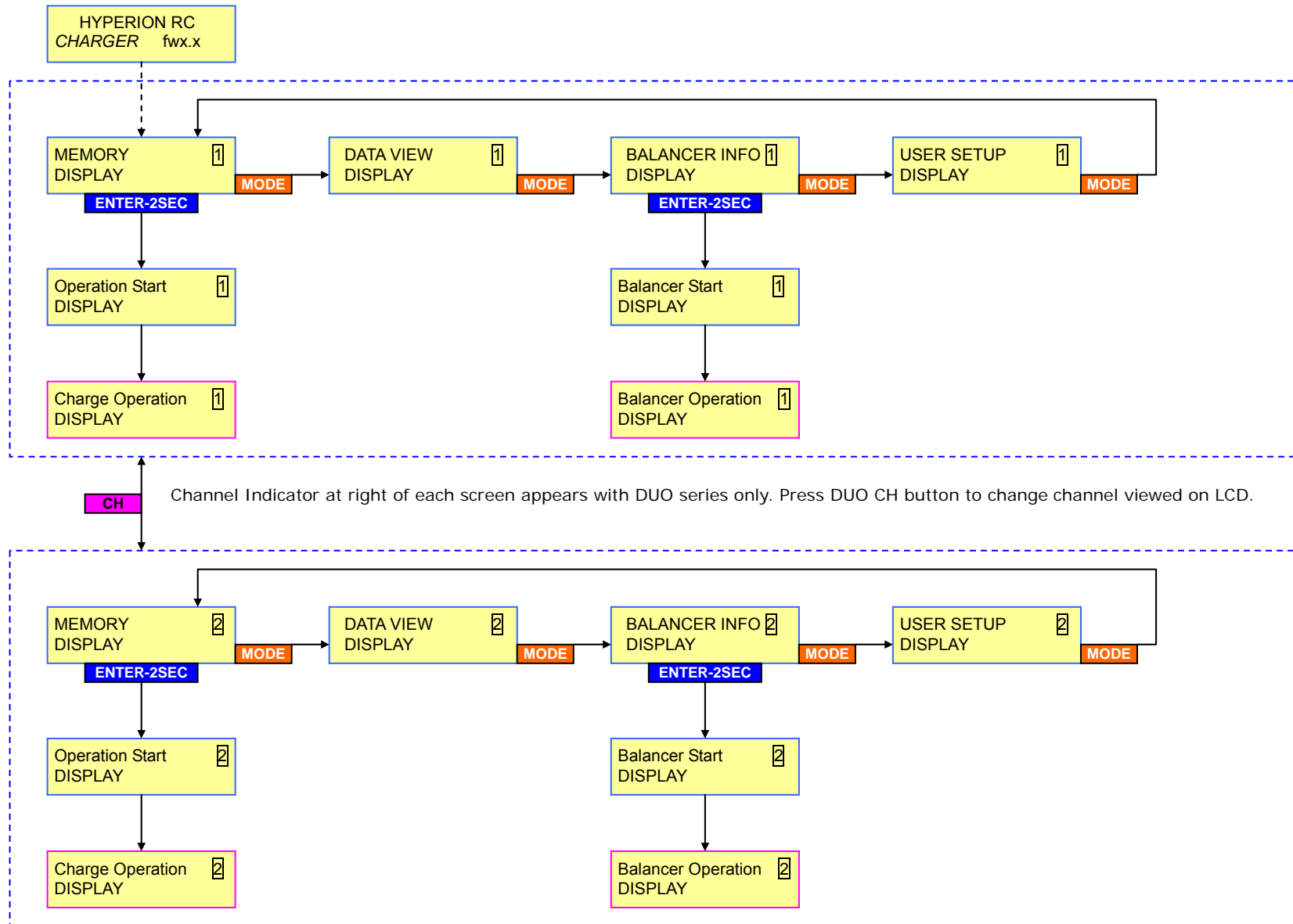

(2) MEMORY DISPLAY (settings available per each memory slot, depending on battery type)

LiIo/LiPo/LiFe

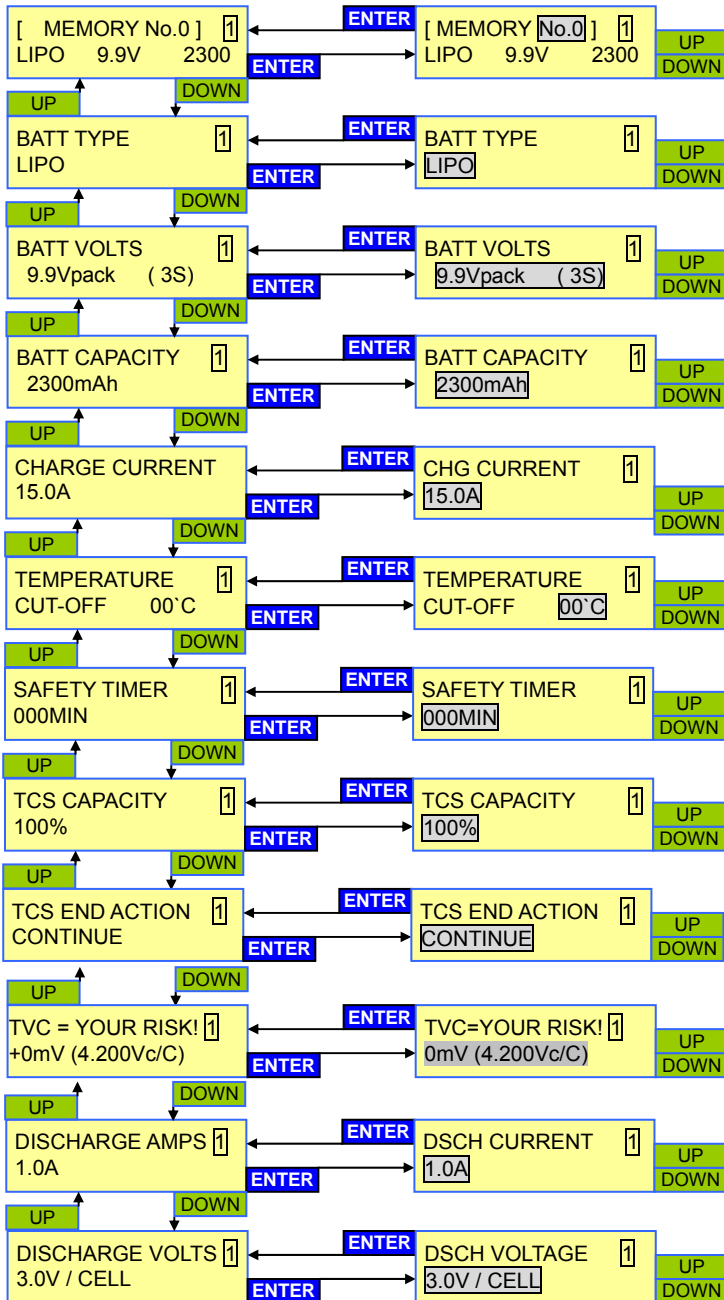

NiCd/NiMH

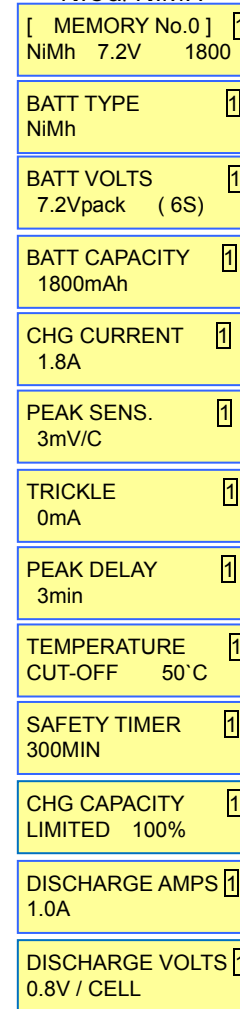

Pb

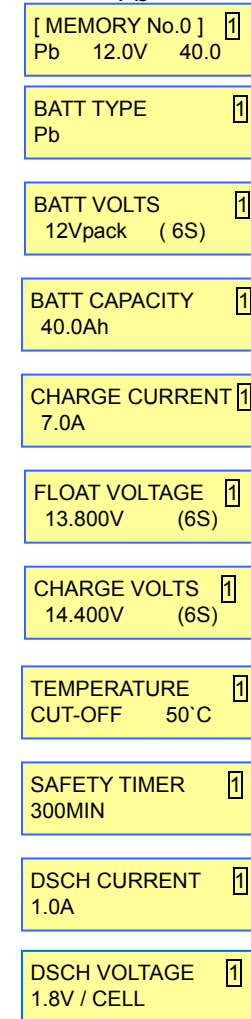

NOTE! NEVER CHANGE TVC SETTING UNLESS YOU ARE AN EXPERT USER, HAVE READ THE DETAILS ON PAGE 12, AND TAKE ALL RISK OF FIRE, DAMAGE, LOSS, or INJURY WHICH MAY RESULT

(3) DATA VIEW DISPLAY

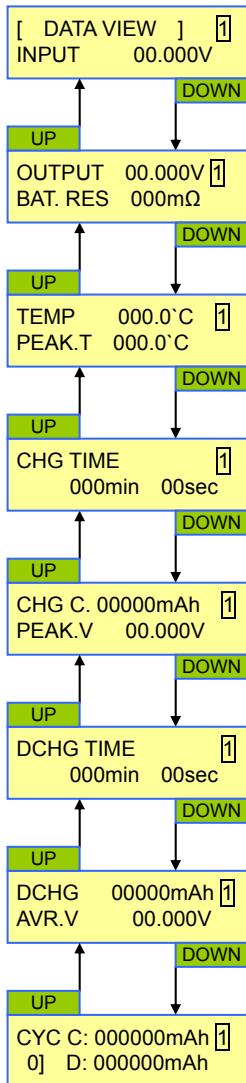

(4) BALANCE INFORMATION DISPLAY

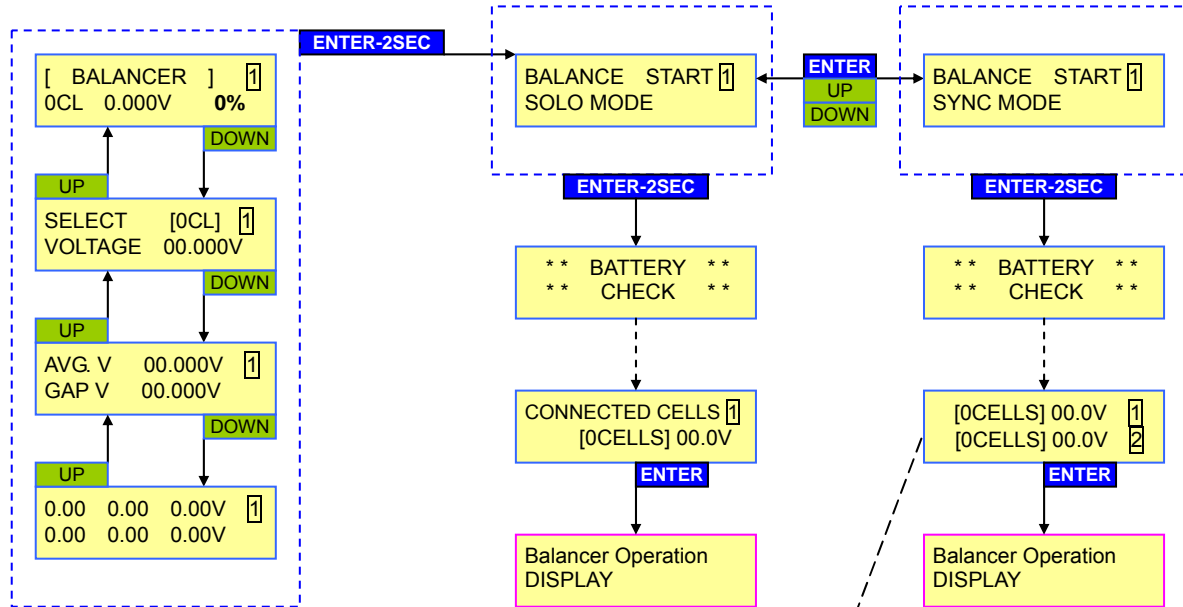

The 0% under [BALANCER] above indicates TCS% (capacity)

10-second AUTO Countdown. Starts charge after 10 seconds if user does not confirm cell count, only during Balance/Charge for Li- types.

(5) USER SETUP DISPLAY

CH#1 Global Settings

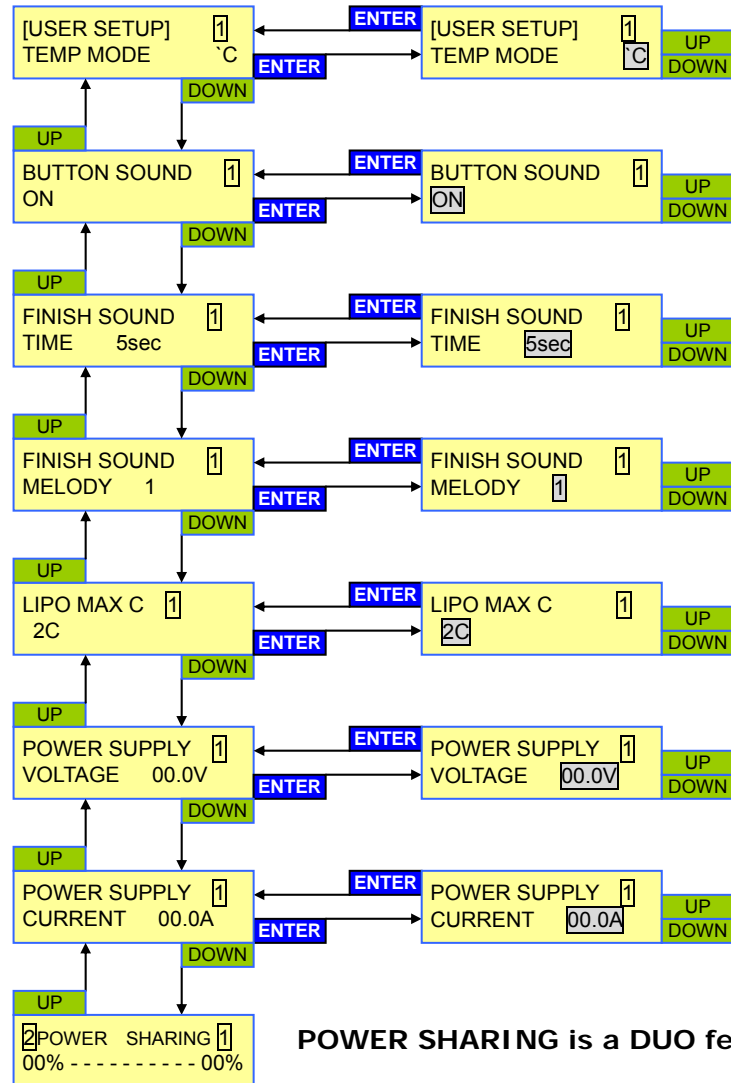

CH#2 Global Settings

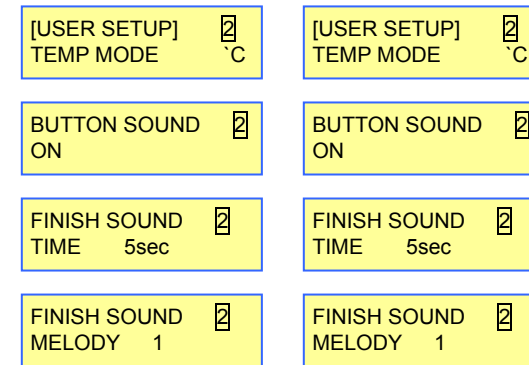

Lipo "Max C" is set to 2C by default. Select 1C to 5C as desired.

The **PS Load Control** settings above and **LIPO MAX C** are only found under CH#1 menu, but are effective for all memory positions on **both channels** for DUO.

OPERATIONS START – SETUP & DISPLAY

(6) NiCd / NiMH BATTERY START

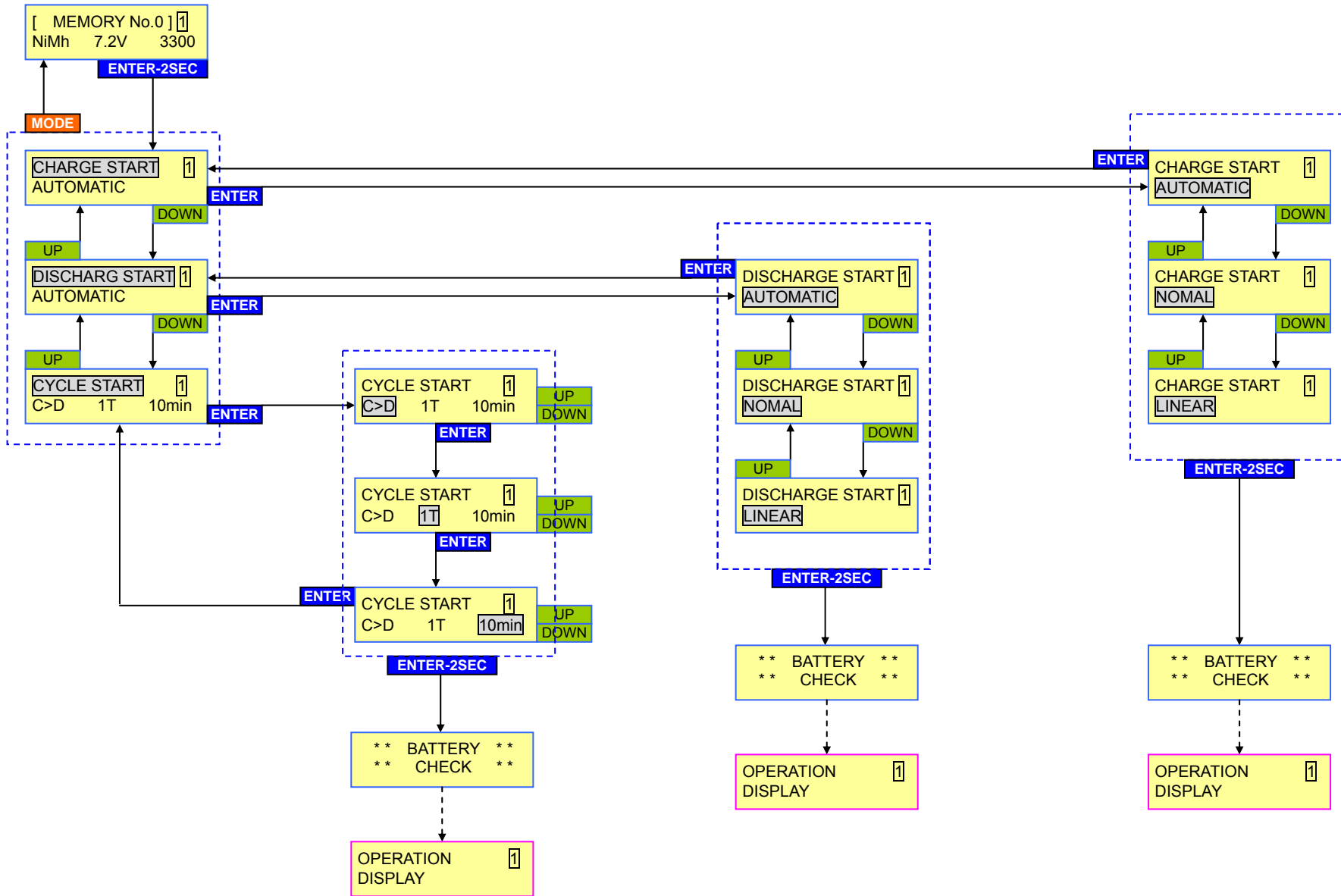

(7) LiIo / LiPo / LiFe) BATTERY START

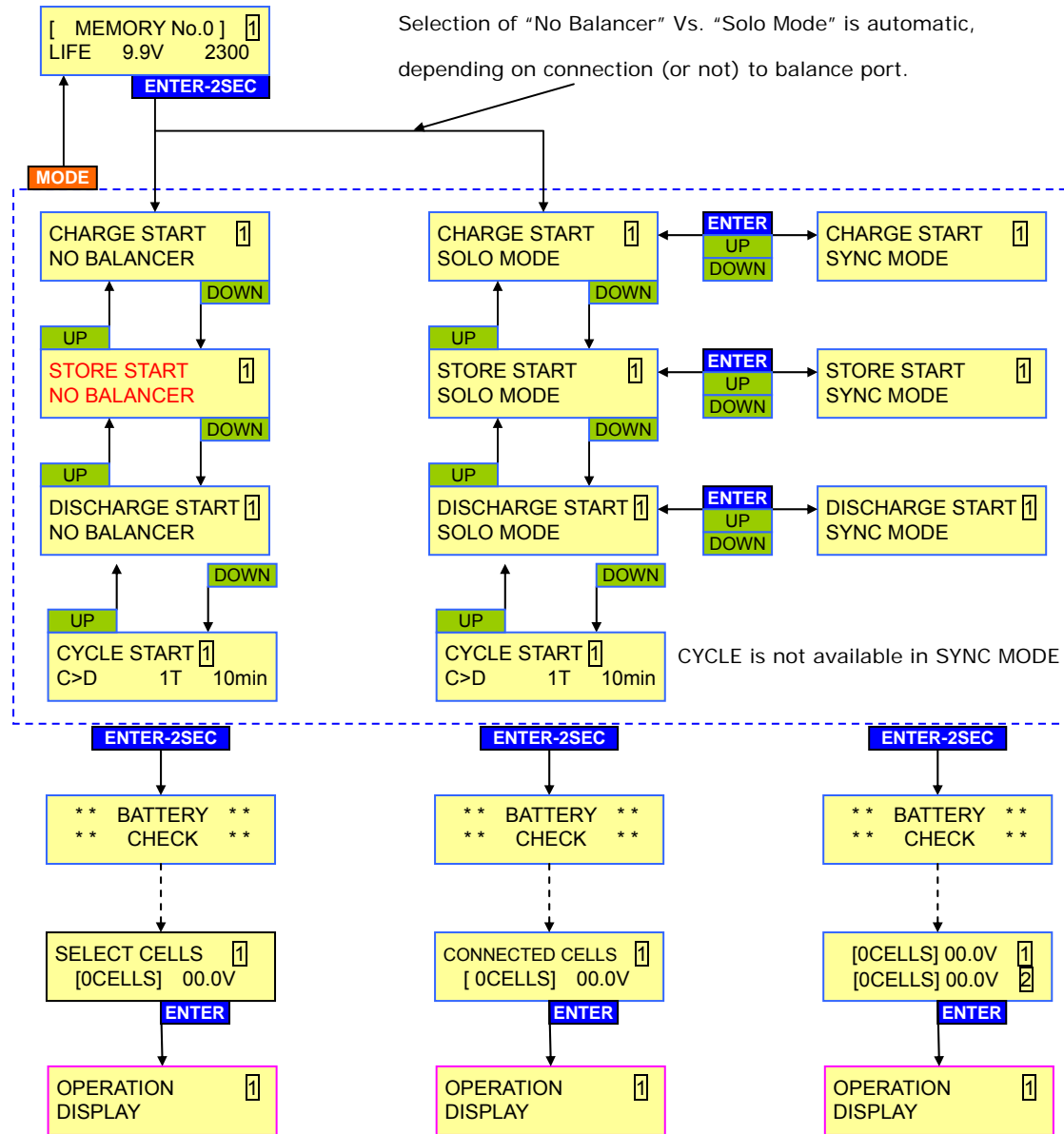

(8) PB BATTERY START

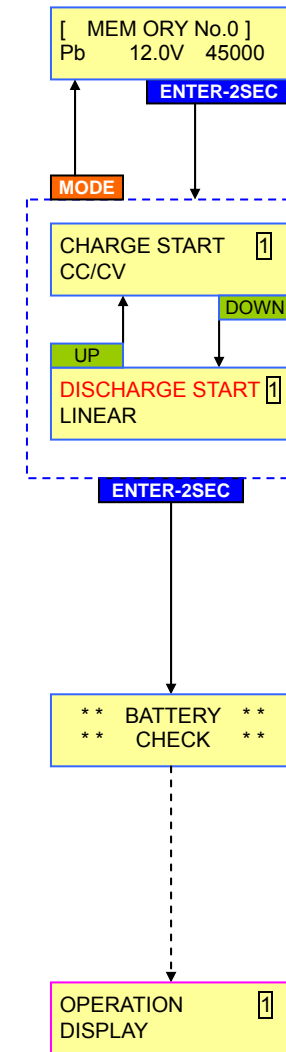

Note: STORE Mode only applies to LiIo, LiPo, and LiFe types. Balancer Connection is **required**. If Balancer is NOT connected OUTPUT BATTERY CONNECT ERROR will result.

(9) OPERATION and FINISH DISPLAY

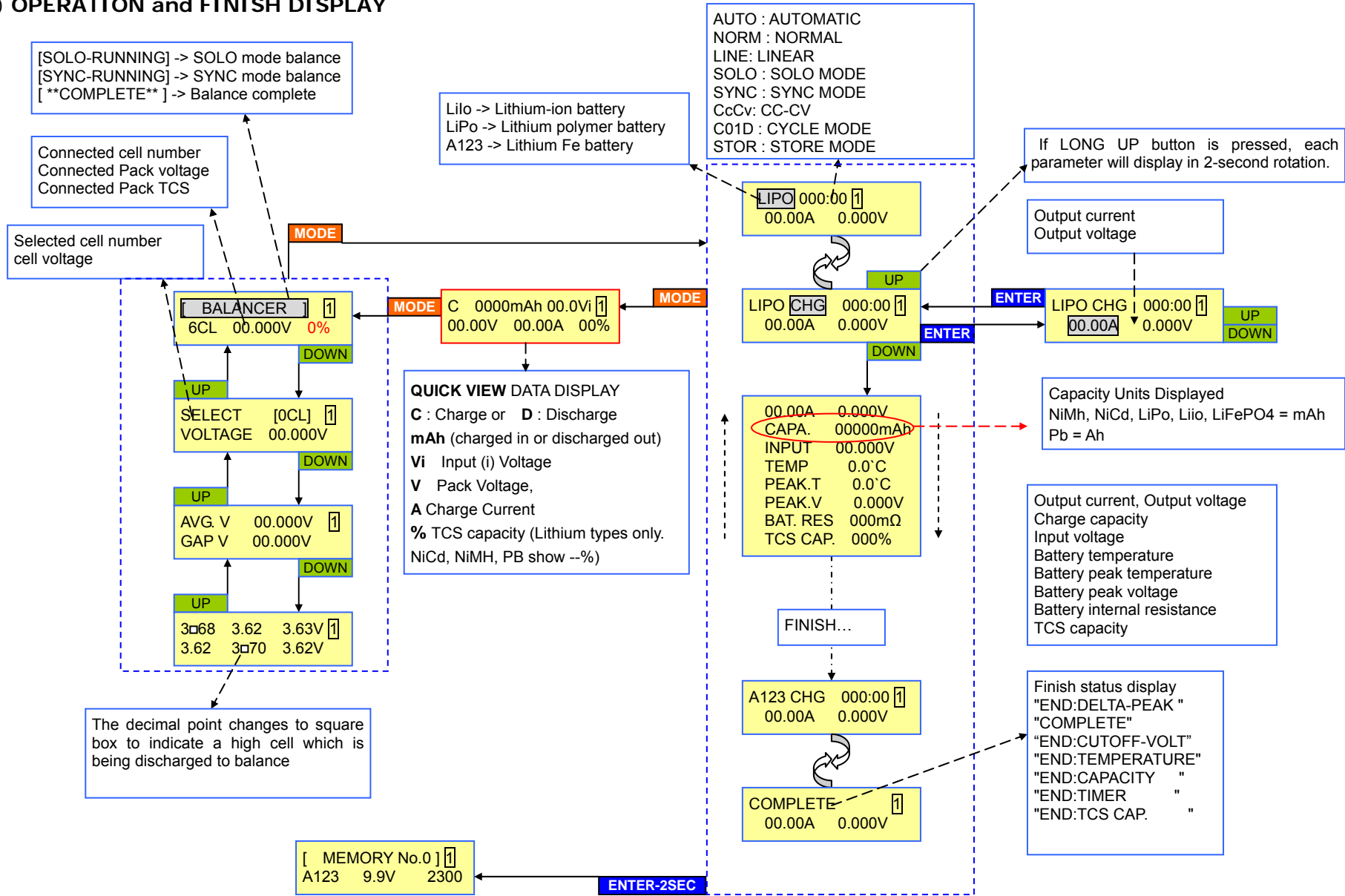

(10) LiIo / LiPo / LiFePO4 (a123) FINISH DISPLAY

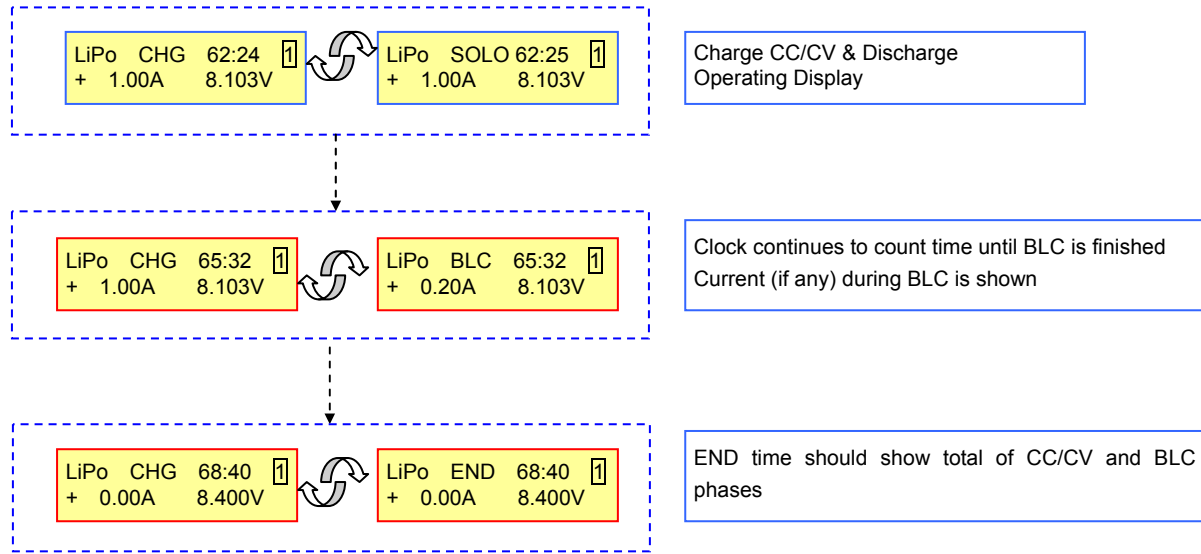

(11) NiCd/NiMH CYCLE OPERATION DISPLAY

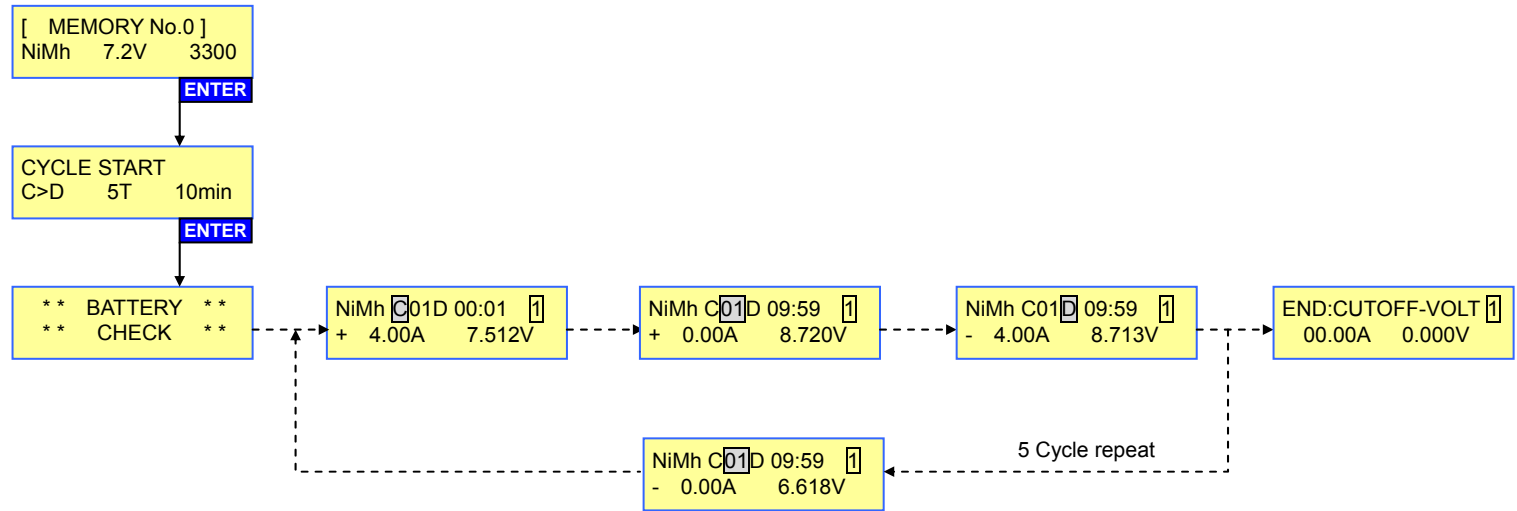

ERROR MESSAGES

INPUT VOLTAGE ERROR 0.00Vi	When input voltage is below 11.0V or exceeds 28V.
OUTPUT BATTERY CONNECT ERROR	When a battery is not connected to the charger's output
OUTPUT BATTERY REVERSE POLARITY	Output battery is connected to the output in reverse polarity (switch +/-)
OUTPUT BATTERY OPEN CIRCUIT	If the battery becomes disconnected during an operation
OUTPUT CIRCUIT ERROR	The output circuit of the charger has a problem. See troubleshooting in text guide.
OUTPUT VOLTAGE TOO LOW 0.00V	Output voltage is lower than the selected cells or voltages (check battery specs and condition, or reset charger correctly)
OUTPUT VOLTAGE TOO HIGH 0.00V	Output voltage is higher than the selected cells or voltages.
TEMPERATURE SENSOR ERROR	The thermal probe is incorrectly connected, or the probe is damaged.
BATTERY TEMP TOO LOW 0.00V	The temperature of the battery is too low (below -10°C at idle mode and 0°C during operation, requires probe attached!).
BATTERY TEMP TOO HIGH	Battery temp is too high to be charged! (requires temp probe attached!)
INTERNAL TEMP TOO HIGH	Internal temp of the charger has exceeded 125C. Reduce ambient temp, wait, restart.
BALANCE VOLTAGE CELL(0) TOO HIGH	A balancing cell's voltage is too high. Possible pack damage or connection error.
PAUSE... CHARGER TOO HOT	Charger temperature is too high. Charger will Pause until temp drops
SYNC COMMAND ERROR	Problem with wiring, connectors, or other. Clean and inspect as in Troubleshooting section for OUTPUT ERROR
FLAT CHECK	NiCd, NiMH only. Charger cannot detect DeltaV to terminate charge. See Troubleshooting section. Try a lower DeltaV setting.

XH type included HP(PQ) type included TP/FP type optional EH type optional

LIPO BALANCE CONNECTOR MULTI-ADAPTERS

EOS NET/DUO chargers all include Hyperion "HP" multi-adapter(s) and also JST XH types. Other types are available as options for purchase. Be sure to consult the chart to right (or ask your pack maker) to determine which adapter should be used with your battery.

6S Chargers use: **HP-EOSLBA-26**-B**
 7S Chargers use: **HP-EOSLBA-7U**-B**

There is also a 6S Adapter for 0615i-DUO3 which fits FMA-brand CellPro Lipo, HP-EOSLBA-26CP-B, available at USA dealers.

0615-DUO3 6S >	HP-EOSLBA-26XH-B	HP-EOSLBA-26HP-B	HP-EOSLBA-26TP-B	HP-EOSLBA-26EH-B
NET3 & SDUO3 7S >	HP-EOSLBA-7UXH-B	HP-EOSLBA-7U-B	HP-EOSLBA-7UFP-B	HP-EOSLBA-7UEH-B
BATTERY BRANDS WHICH FIT EACH ADAPTER TYPE	ALIGN	HYPERION	THUNDER POWER	KOKAM
	DUALSKY	POLYQUEST	FLIGHTPOWER-EVO	GRAUPNER
	E-FLIGHT	E-TEC	APEX	ROBBE
	ELECTRIFLY	POLY RC	VISLERO	NEU
	HEXTRONIC,TURNIGY	XCITE	DANLIONS	APOGEE
	ESKY	MAX AMPS	MPX	VAMPOWER
	VENOM	TRUE RC		
	AIR THUNDER	IMPULSE		
	KONG THUNDER			
	GRAYSON POWER			
	TENERGY			
	DN POWER			
	MEGA POWER			
	ELECTRIC POWER			
	TURBORIX			
	ENERGY EC, WOW RC			
	IMAX			
	FULLY MAX, FUSION			
	ZIPPY			