

# HYPERION EOS0720iNET3 Layout & Sync Network Setup (v3.2 firmware version)

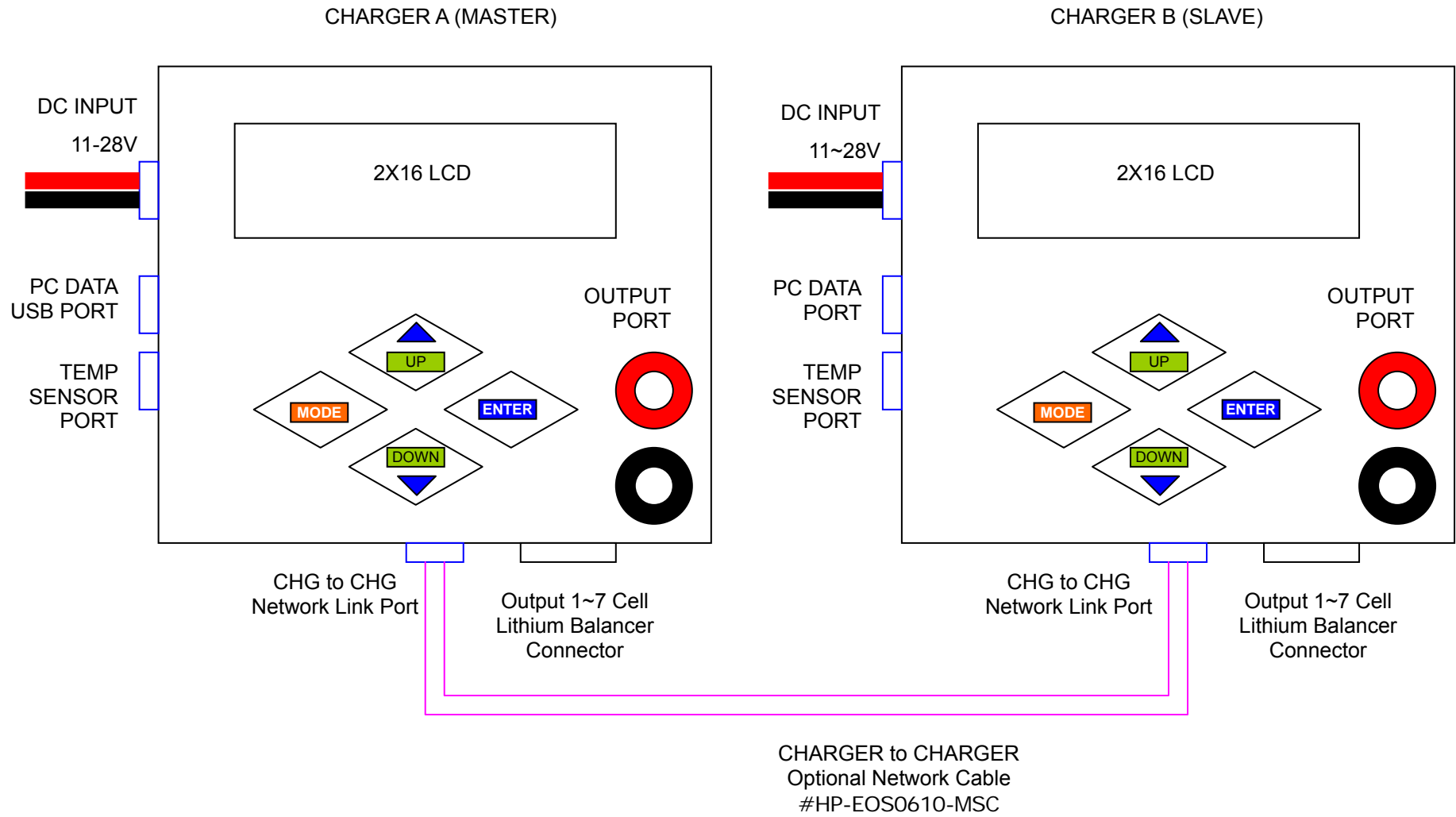

(1) MAIN MENU FLOW

(note: whichever charger is used to select SYNC mode becomes the "master")

MASTER

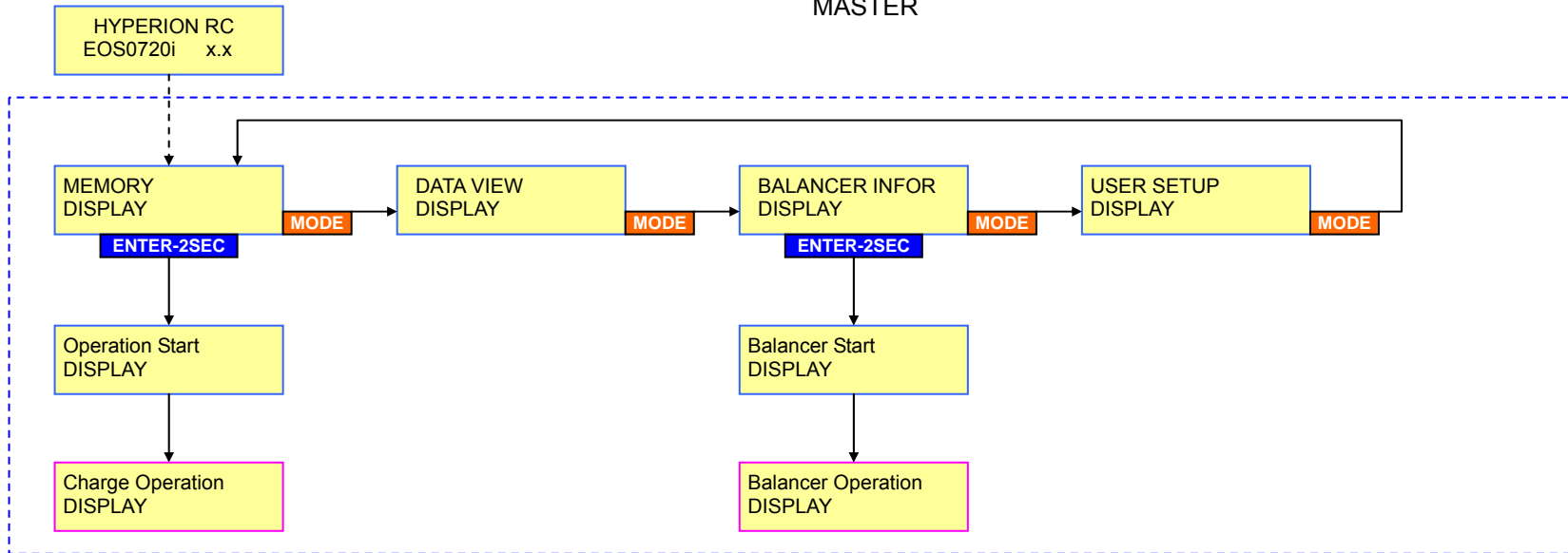

SLAVE

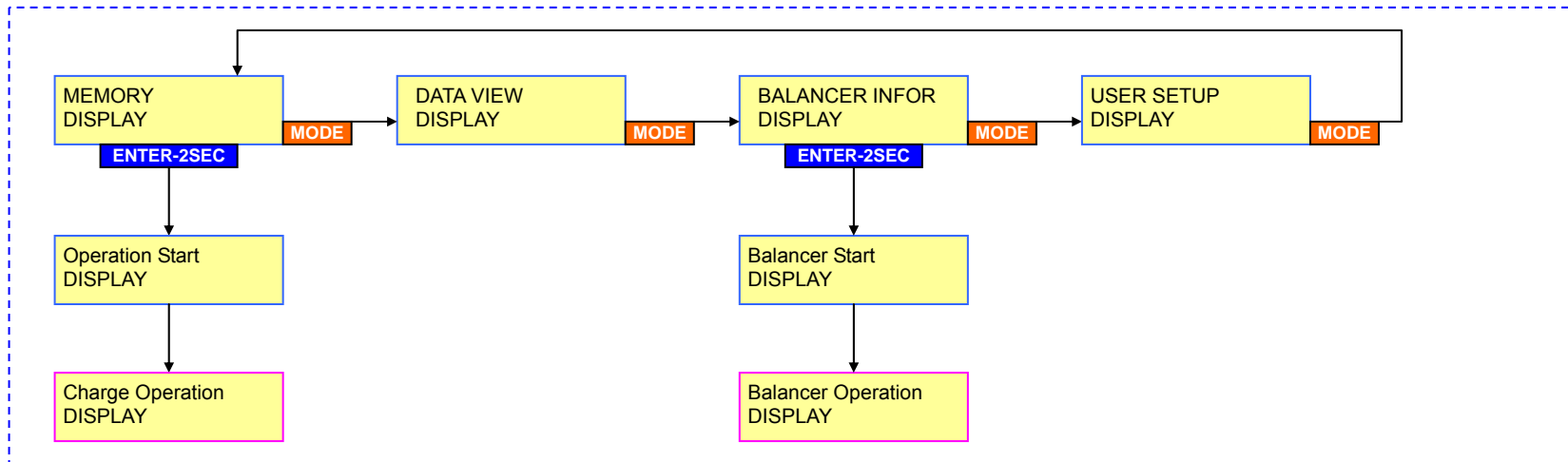

(2) **MEMORY DISPLAY** (settings available per each memory slot, depending on battery type)

LiIo/LiPo/LiFePO4 (a123)

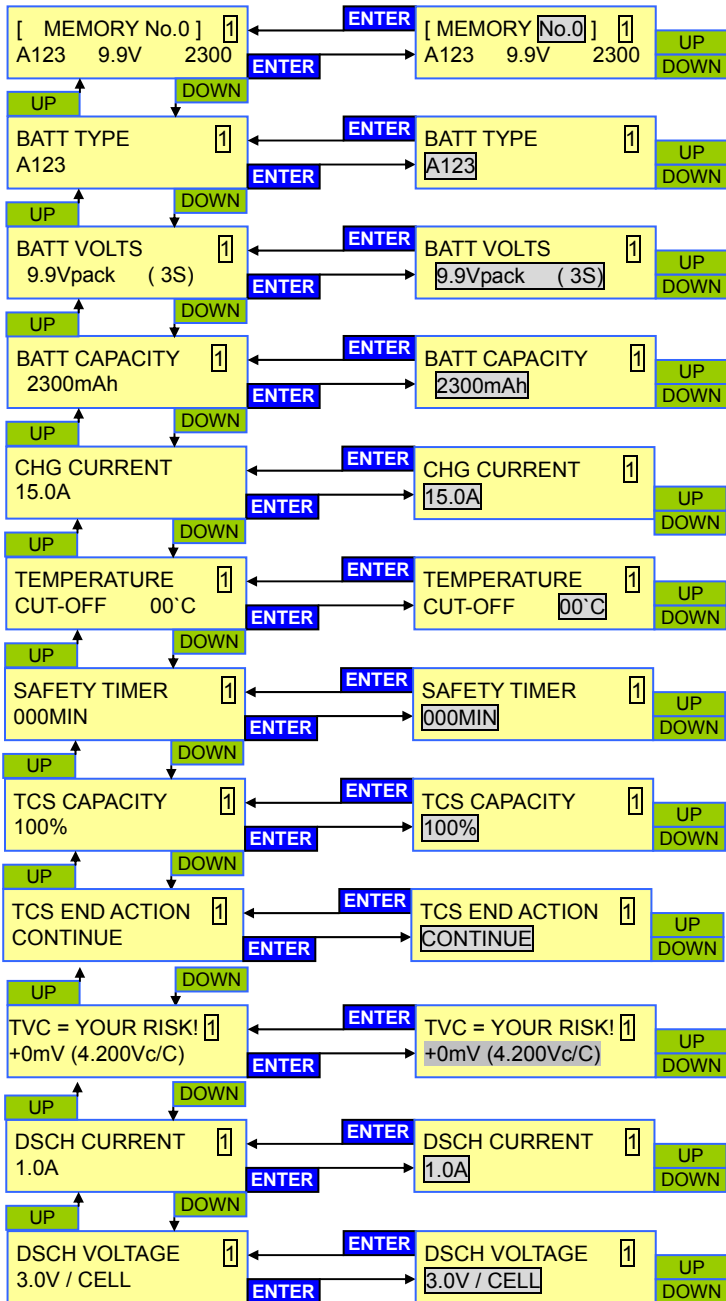

NiCd/NiMH

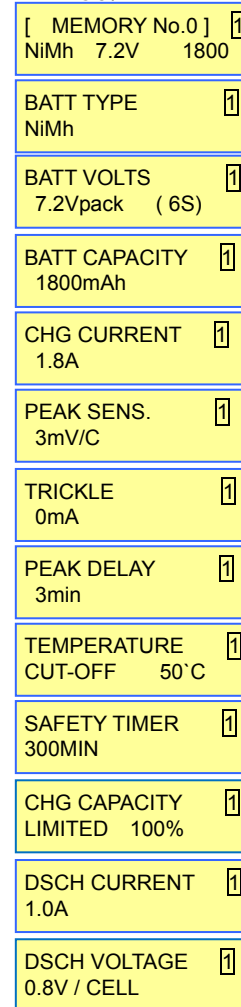

Pb

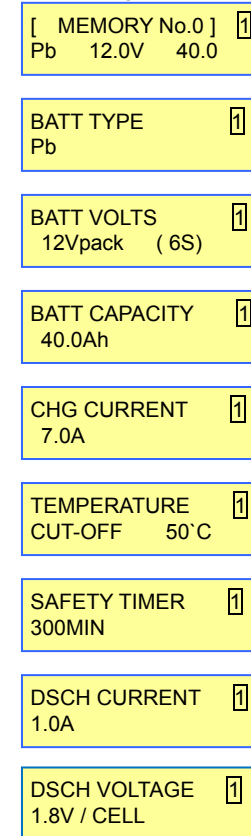

NOTE! NEVER CHANGE TVC SETTING UNLESS YOU ARE AN EXPERT USER, HAVE READ THE DETAILS ON PAGE 12, AND TAKE ALL RISK OF FIRE, DAMAGE, LOSS, or INJURY WHICH MAY RESULT

(3) DATA VIEW DISPLAY

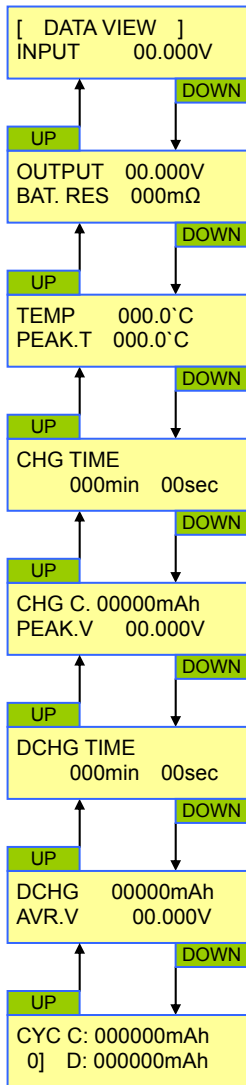

(4) BALANCE INFORMATION & START DISPLAY

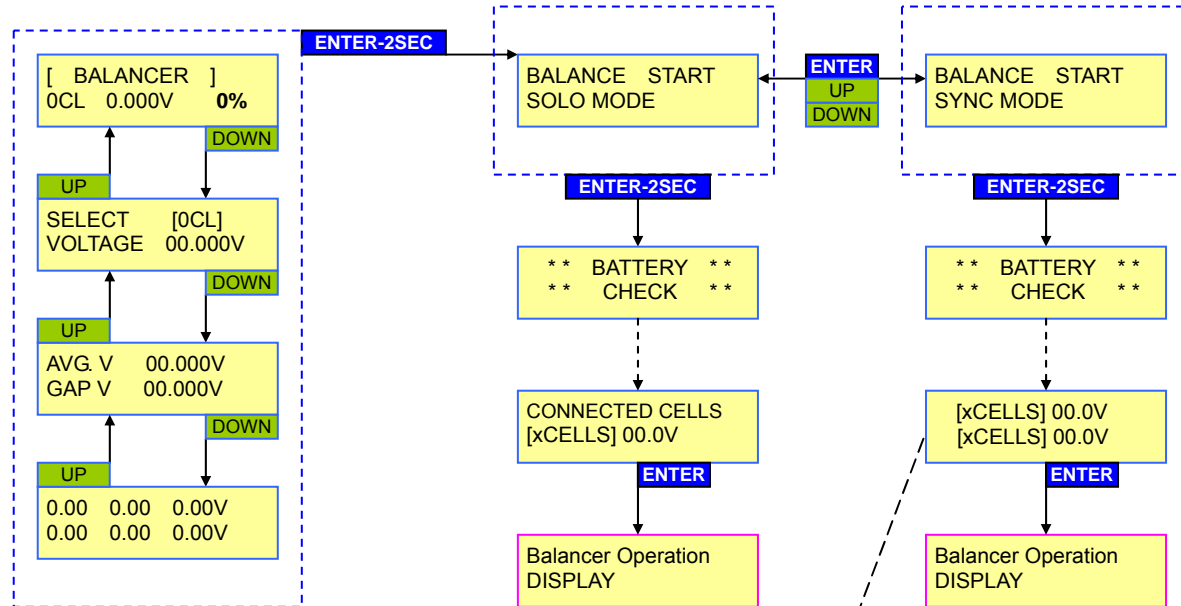

The 0% under [ BALANCER ] above indicates TCS% (capacity)

10-second AUTO Countdown. Starts charge after 10 seconds if user does not confirm cell count, only during Balance/Charge for Li~ types.

## (5) USER SETUP DISPLAY

Global Settings

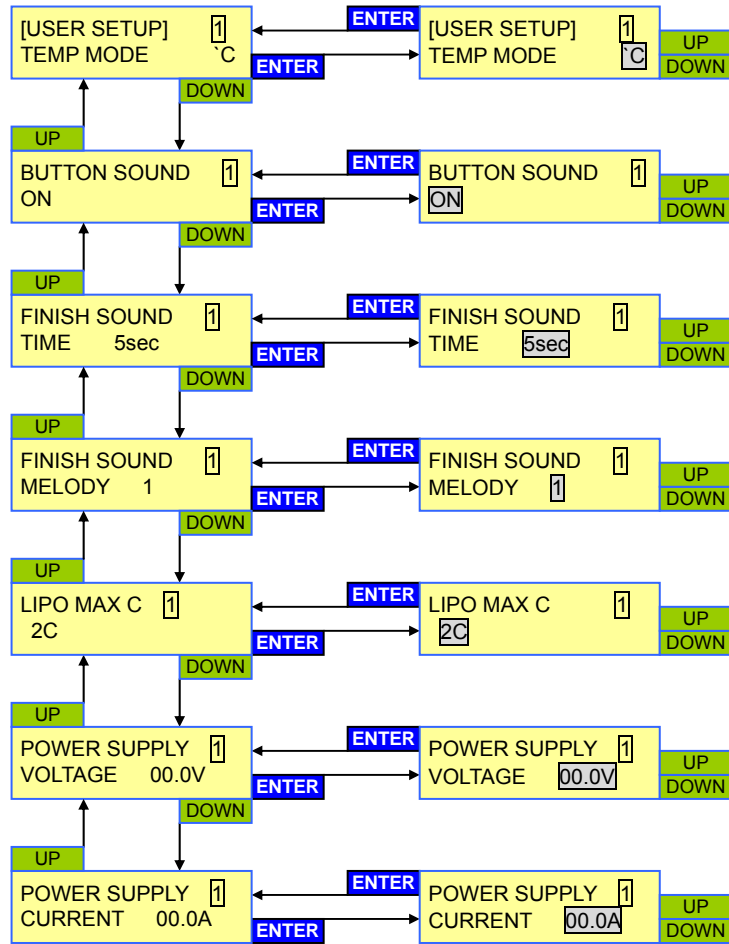

Lipo "Max C" is set to 2C by default. Select 1C to 5C as desired.

# OPERATIONS START – SETUP & DISPLAY

## (6) NiCd / NiMH BATTERY START

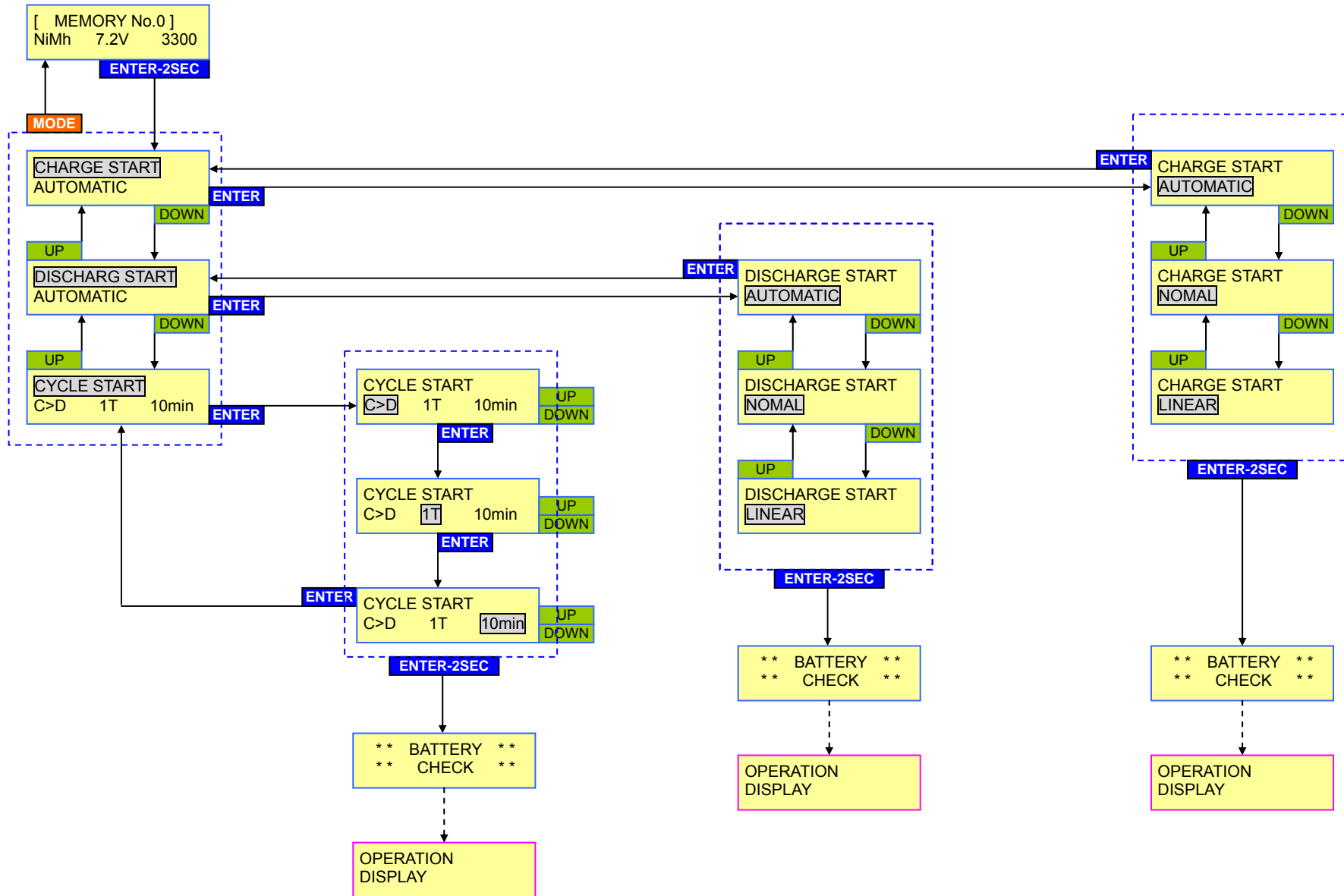

### (7) LiIo / LiPo / A123 BATTERY START

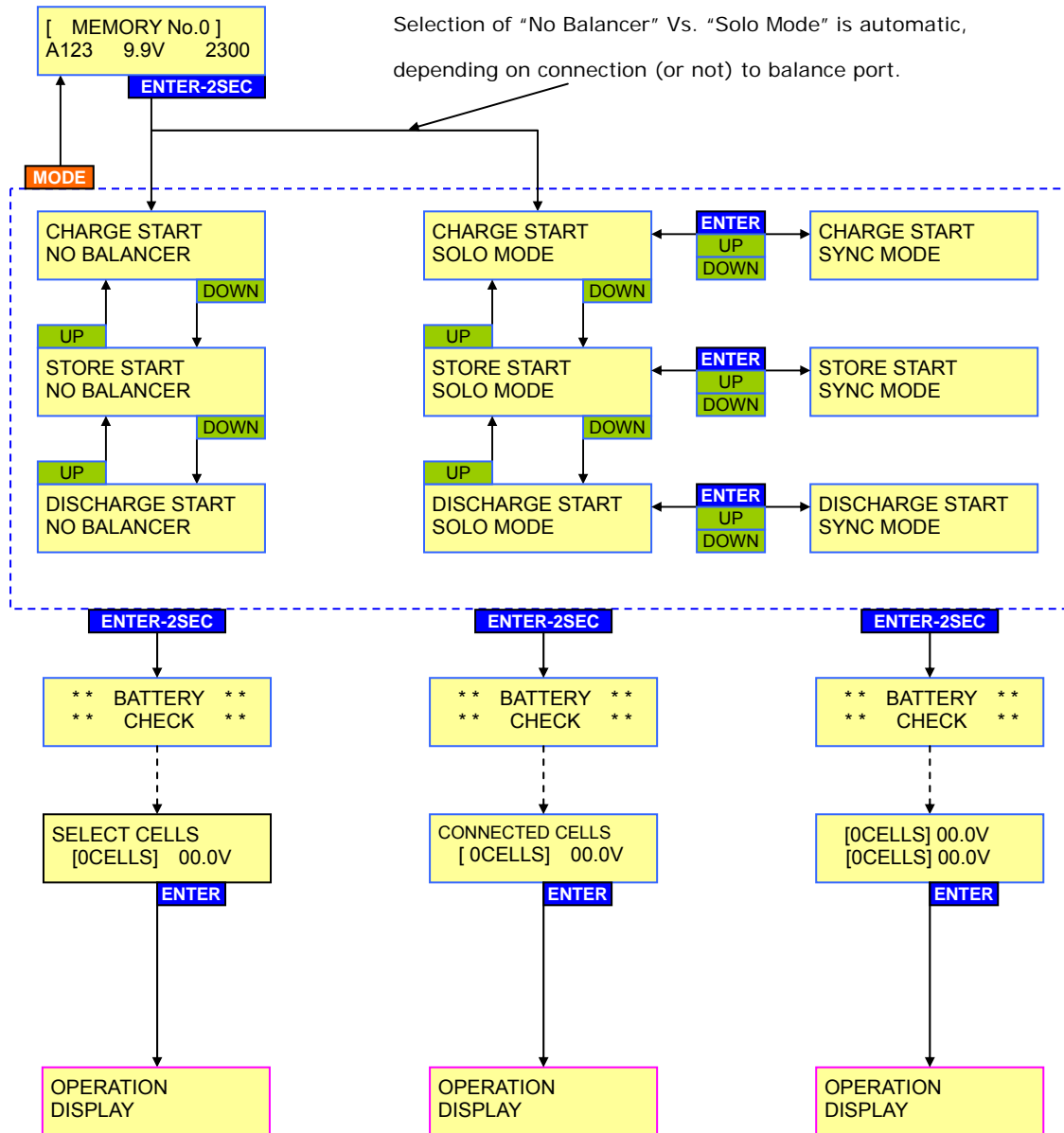

### (8) PB BATTERY START

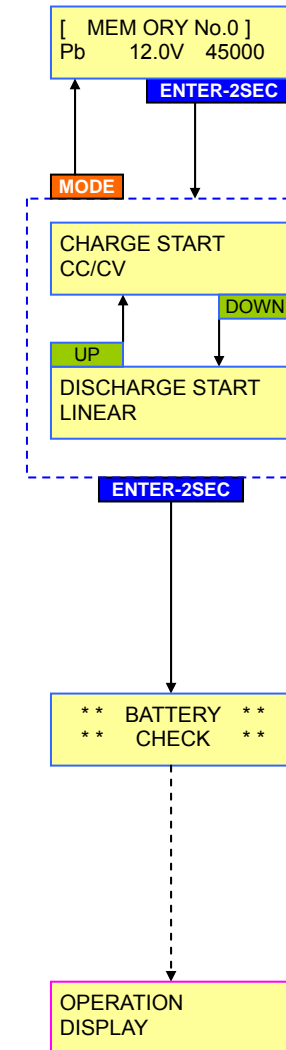

**Note:** STORE Mode only applies to LiIo, LiPo, and LiFePO4(a123) types only. Balancer Connection is **required**. If Balancer is NOT connected OUTPUT BATTERY CONNECT ERROR will result.

(9) OPERATION and FINISH DISPLAY

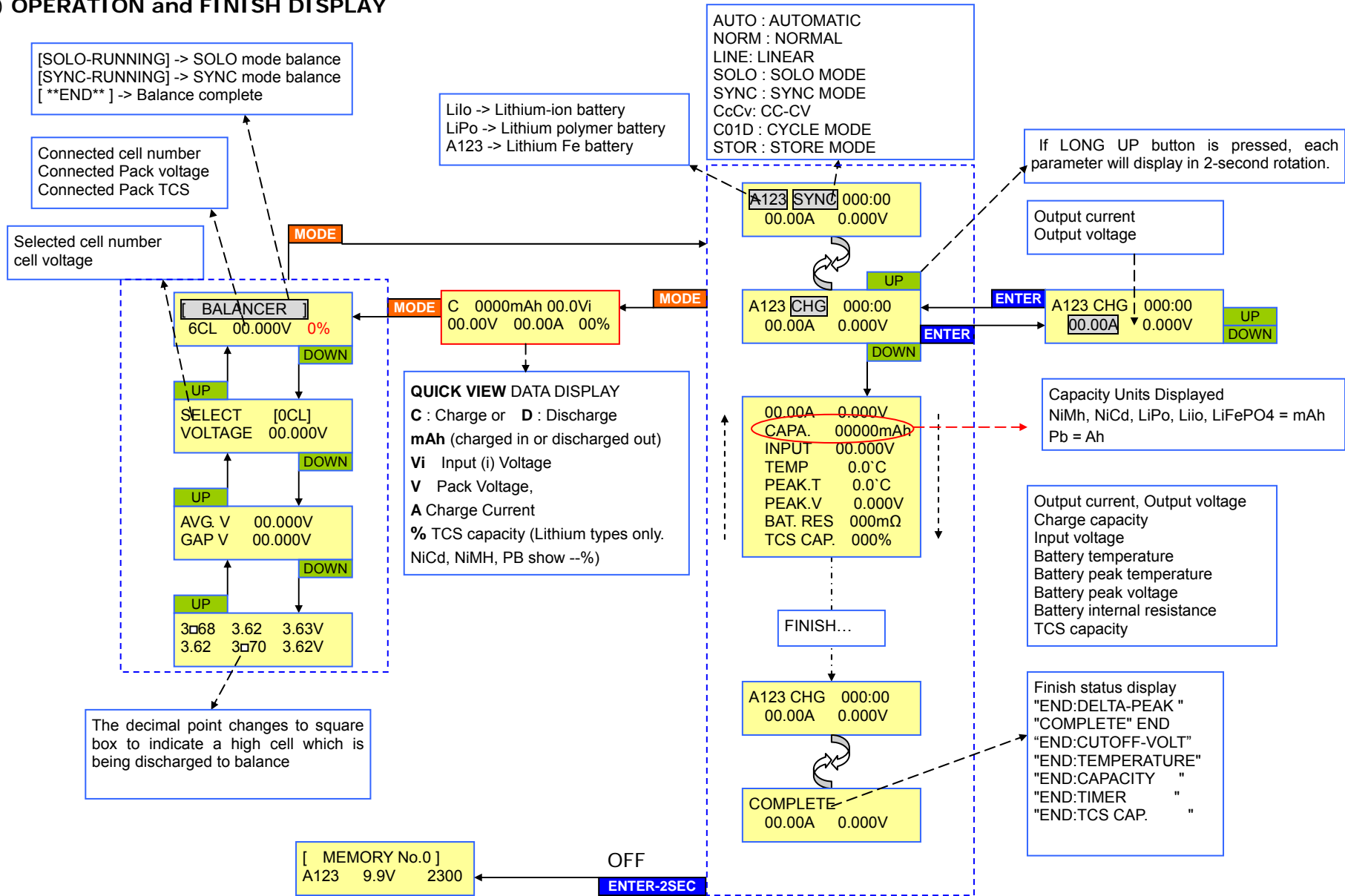

(10) **LiIo / LiPo / LiFePO4 (a123) FINISH DISPLAY**

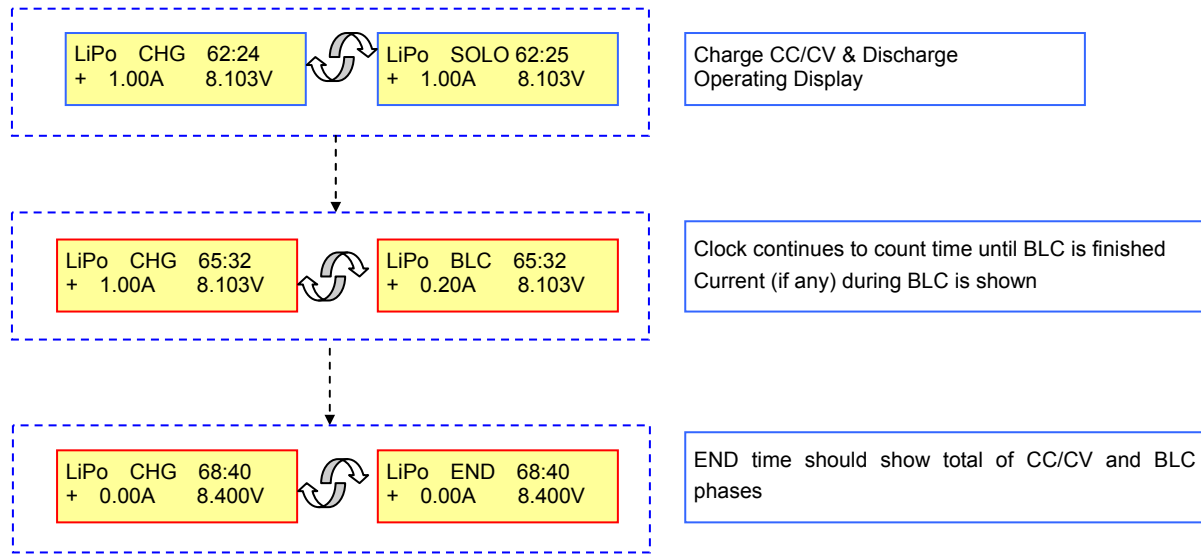

(11) **NiCd/NiMH CYCLE OPERATION DISPLAY**

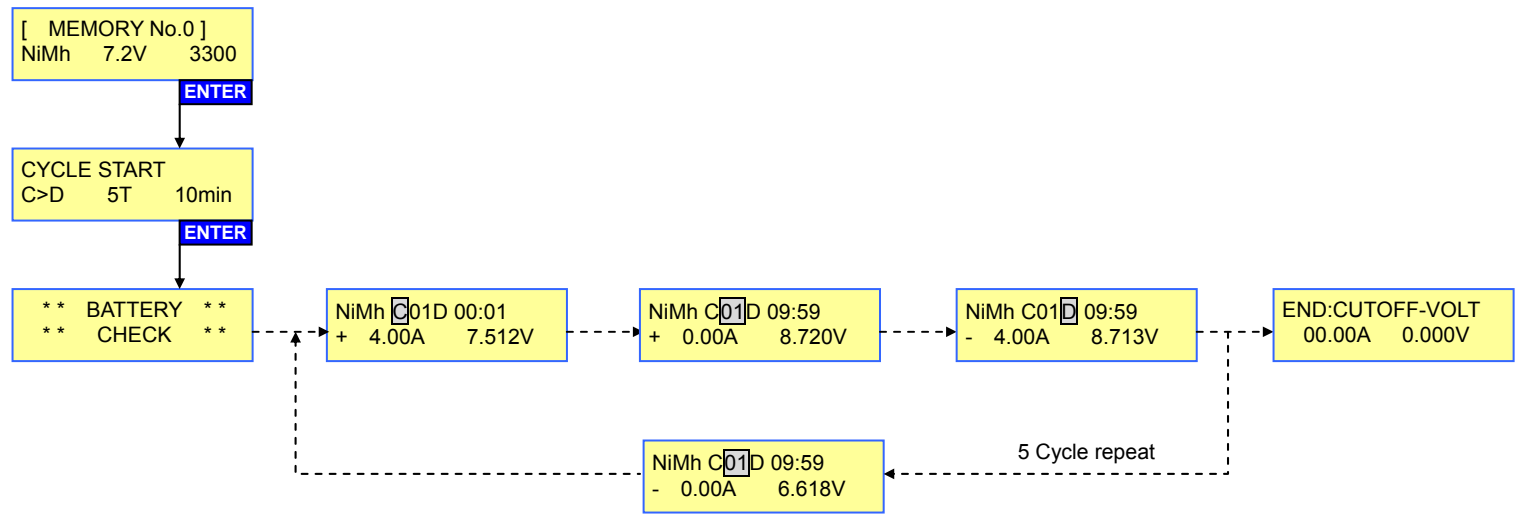

## ERROR MESSAGES

INPUT VOLTAGE ERROR 0.00Vi	When input voltage is below 11.0V or exceeds 28V.
OUTPUT BATTERY CONNECT ERROR	When a battery is not connected to the charger's output
OUTPUT BATTERY REVERSE POLARITY	Output battery is connected to the output in reverse polarity (switch +/-)
OUTPUT BATTERY OPEN CIRCUIT	If the battery becomes disconnected during an operation
OUTPUT CIRCUIT ERROR	The output circuit of the charger has a problem. See troubleshooting above.
OUTPUT VOLTAGE TOO LOW 0.00V	Output voltage is lower than the selected cells or voltages (check battery specs and condition, or reset charger correctly)
OUTPUT VOLTAGE TOO HIGH 0.00V	Output voltage is higher than the selected cells or voltages.
TEMPERATURE SENSOR ERROR	The thermal probe is incorrectly connected, or the probe is damaged.
BATTERY TEMP TOO LOW 0.00V	The temperature of the battery is too low ( below -10°C at idle mode and 0°C during operation, requires probe attached!).
BATTERY TEMP TOO HIGH	Battery temp is too high to be charged! (requires probe attached!)
INTERNAL TEMP TOO HIGH	When the temperature of the charger exceeds 125C. Reduce ambient temp, wait, restart.
BALANCE VOLTAGE CELL(0) TOO HIGH	When the balancing cell voltage is too high. Possible pack damage or connection error.
PAUSE... CHARGER TOO HOT	Charger temperature is too high. Charger will Pause until temp drops
SYNC COMMAND ERROR	Problem with wiring, connectors, or other. Clean and inspect as in Troubleshooting section for OUTPUT ERROR
FLAT CHECK	NiCd, NiMH only. Charger cannot detect DeltaV to terminate charge. See Troubleshooting section in text manual.

## CONNECTOR WIRING FOR HYPERION-COMPATIBLE PACKS

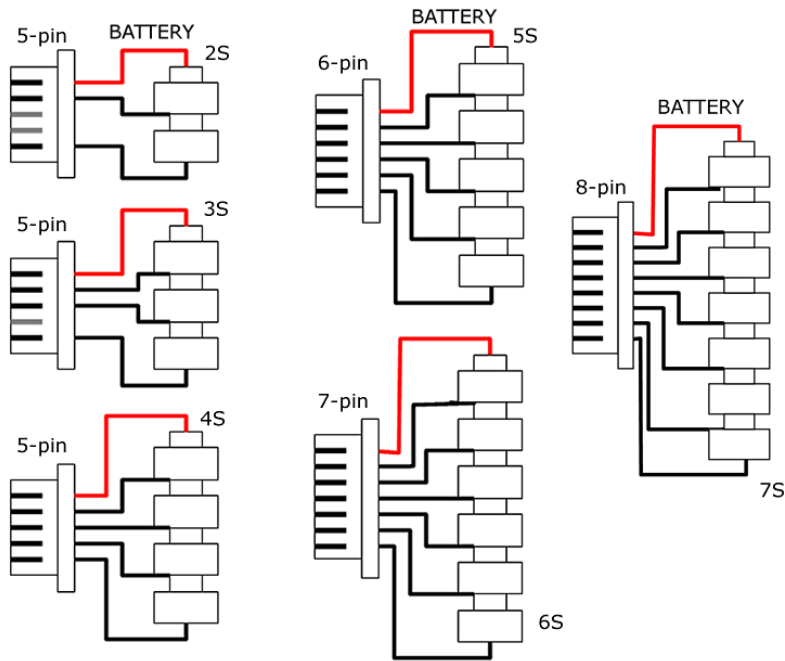

\* Note: NET3 chargers all include Hyperion "HP" multi-adapter. Depending on country of purchase, NET3 may also include an "XH" adapter (HP-EOSLBA-7UXH-B) or EH type (HP-EOSLBA-7UEH-B). If so, be sure to consult the chart to right or your pack maker to determine which adapter should be used with your battery.

NET3 Comes with a HYPERION compatible Multi-adapter to fit 2S to 7S packs (#HP-EOSLBA-7U-B). \* Other brand adapters are available as option parts, # HP-EOSLBA-7Uxx-B as below: IF YOUR PACK MAKER IS NOT LISTED BELOW, ASK THE MAKER WHICH BRAND BELOW IT MATCHES.

HP-EOSLBA-7UXH-B	HP-EOSLBA-7U-B	HP-EOSLBA-7UFP-B	HP-EOSLBA-7UEH-B
ALIGN	HYPERION	THUNDER POWER	KOKAM
DUALSKY	POLYQUEST	FLIGHTPOWER-EVO	GRAUPNER
E-FLIGHT	E-TEC	APEX	ROBBE
ELECTRIFLY	POLY RC	VISLERO	NEU
HEXTRONIC	XCITE	DANLIONS	APOGEE
COMMON SENSE V1	MAX AMPS	MPX	VAMPOWER
COMMON SENSE V2	TRUE RC		
ESKY	IMPULSE		
VENOM			
AIR THUNDER			
KONG THUNDER			
GRAYSON POWER			
TENERGY			
DN POWER			
MEGA POWER			
ELECTRIC POWER			
TURBORIX			
ENERGY EC, WOW RC			
IMAX			
FULLY MAX			
FUSION			

## **HYPERION 0720iNET, 0610iDUO2, 0720iNET3, 0615iDUO3 TVC FUNCTION**

(Terminal Voltage Control per each memory slot, for LIPO and LIFE/A123)

The TVC function allows adjustment of final CHARGE voltage for LIPO and LIFE battery types for each memory position:

+0mV (default, therefore no change. Lipo=4.200V terminal, LIFE(A123)=3.600V terminal)

+5mV to +80mV (5mV steps, so LIPO for example terminates at 4.205V~4.280V)

-5mV to -20mV (5mV steps, so LIPO for example terminates at 4.195V~4.180V)

The TVC Function is found in every memory slot for Lipo and Life, below TCS ACTION setting screen. Note that the TVC settings are RETAINED, like other Memory settings, when the charger is powered off. Be SURE that this setting is correct before using any LIPO or LIFE memory slot (Default TVC=0mV strongly recommended).

Note: After confirming CELL COUNT and START for LIPO/LIFE charging, if TVC setting is not default, current TVC setting will be shown for a few seconds before the charger begins the charge. Be sure to note the displayed TVC setting at this time, and STOP the charge to reset TVC to default whenever so desired.

### **Uses for TVC FUNCTION:**

**-5mV to -20mV:** Reducing Terminal Voltage should only be done in case MEASURED cell voltage at your battery pack (with quality digital voltmeter) shows Terminal voltage exceeding 4.2V for Lipo (or default 3.6V for LIFE/A123 types). This essentially acts as a calibration function, and should normally be unneeded when using EOS standard, supplied output leads and balance harnesses. However, if you have made your own longer harnesses, the additional length in leads creates the possibility of extra induced resistance, and therefore a reading at the charger lower than is actually found at the battery. This could cause an over-voltage charge. If you find terminal voltage over 4.2V/cell for any LIPO cell, reduce TVC setting on each memory position until your MEASURED max cell voltage (at battery) is at 4.2V or lower if LIPO, or 3.6V or lower if LIFE.

**+5mV to +80mV:** Ability to set terminal voltage above defaults is only at the request of competition car, boat, and aircraft users, and only if the race sanctioning body allows terminal voltage for Lipo above 4.2V, or LIFE(A123) above 3.6V.

No LIPO battery maker or seller recommends or allows Terminal Voltage to be set higher than 4.200V, to our knowledge. Hyperion does not recommend or allow G3 Lipo Terminal Voltage to be set higher than 4.200V. Therefore any + setting above 0mV VOIDS your WARRANTY for your LIPO battery pack. Whenever ALL cells in a pack exhibit puffing, over-voltage charging is indicated and warranty will not be honored.

**WARNING!** By setting the TVC to any POSITIVE SETTING above 0mV, you **ACCEPT ALL RESPONSIBILITY** for Damage to your battery, Fire, Injury, and any other Loss which may result. **If you do not agree to accept all risk, DO NOT OPERATE YOUR CHARGER UNLESS ALL MEMORY POSITIONS ARE SET TO DEFAULT 0mV TVC position!** Furthermore, it is your responsibility to insure that no other person uses your charger if TVC is set to greater than +0mV, and to reset ALL memory positions to TVC 0mV default before selling your charger or giving it to others.

Positive settings (+5mV or higher) may be desired by racers looking for competitive advantage, and therefore +TVC has been demanded as a feature by racers. However, it is the official position of Hyperion that Competition Sanctioning Bodies are irresponsible in allowing over-voltage charging via their rulebooks, and therefore that both users and their sanctioning bodies are FULLY responsible for any Loss, Damage, or Injury that may occur due to over-voltage charging of batteries. Let's say it again: If you want to use Positive TVC settings, you may make that choice. But **ONLY** if you personally deem it desirable, **AND** you are taking **FULL RESPONSIBILITY** for **any** and **all results** which may arise. We encourage you to petition your sanctioning body to STOP allowing LIPO terminal voltages in excess of 4.200V, which are both potentially unsafe and without significant benefit, we believe.